

Pandora International



Pogle Platinum Installation Manual

About this manual

This manual contains important technical information for the Pandora Pogle Platinum Colour Correction Control Systems.

Please read this document before attempting to install or service the equipment described.

Published by

Pandora International Limited
The Old Rectory
Springhead Road
Northfleet
Kent
England

Tel: +44 (0) 1474 561000
Fax: +44 (0) 1474 566935
Website: <http://pogle.pandora-int.com>

Copyright

Copying of this document & giving it to others, & the use or communication of the contents thereof, are forbidden without the expressed authority. Offenders are liable to the payment of damages. All rights are reserved in the event of the grant of a patent or the registration of a utility model or design. Liable to technical alterations in the course of further development.

Für diese Unterlage behalten wir uns alle Rechte vor (Gemäß DIN 34).
Technische Änderungen im Zuge der **Weiterentwicklung vorbehalten.**

Toute communication ou reproduction de ce document, toute exploitation ou communication de son contenu sont interdites, sauf autorisation expressé. Tout manquement à cette règle est illicite et expose son auteur au versement de dommages et intérêts. Tous nos droits sont réservés pour le cas de la délivrance d'un brevet ou de l'enregistrement d'un modèle d'utilité. Sous réserve de modification au cours **de l'évolution technique.**

Contents

Safety Instructions	4
Unit Functional Description	7
Equipment Location	9
Equipment Dimensions	11
Pogle Installation - General.....	14
Rack Mounting	14
Mains Power Wiring	15
Pogle Rack Connections	16
Control Panel Connections	18
System Sync Pulses.....	20
Timing Pulse Adjustment for PBX6002	21
RS422 Cables	22
Cintel Ursa Series Interface.	23
Pogle to Ursa Connections	24
PBX6001 & PBX 6002 Rear Panel	24
Cintel C-Reality & Rascal Interface.....	25
Pogle to C-Reality/ Rascal Connections	26
PBX6001 & PBX 6002 Rear Panel	26
Thompson/ Philips Spirit & Shadow Interface.....	27
Pogle to Spirit/ Shadow Connections	29
PBX6001 & PBX6002 Rear Panel	30
Thompson/ Philips Specter Interface.....	30
ITK Millennium Interface	31
Pogle to Millennium Connections	32
PBX6001 & PBX6002 Rear Panel	32
Sony Vialta Interface.....	33
PBX6001 & PBX6002 Rear Panel	33
Pogle to Vialta Connections	34
DAV Cineglyph Interface.....	35
PBX6001 & PBX6002 Rear Panel	36

Safety Instructions

1 Units Covered

Pogle Workstation: Type PBX6001
Pogle Interface: Type PBX6002
Pogle Control Desk: Type PBX5000

2 Input Voltage & Current



PBX6001 + PBX6002

2.1 Line Voltage : 100-250VAC @ 50/60Hz
Auto Range Sensing by Power Supply Unit.
2.3 VA Rating : 110VA @ 110V , 140VA @ 240V

PBX5000

2.4 Line Voltage : 100-110VAC @ 60Hz
220-240VAC @ 50Hz
Manual Voltage Selection by Internal Link.
2.5 Line Current : 1A Max @ 240V
2.6 VA Rating : 110VA @ 110V , 140VA @ 240V



CAUTION! Severe damage to the Internal Power Supply will result if connection to Input Voltages other than those specified occur. In the case of PBX5000 Control Panel make sure that the voltage selection link is installed correctly before connecting the power supply.

3 Fuses

3.1 Fuse Type

PBX6001 + PBX6002

3.1.1 For 240V operation: 250V T2A Slow Blow Ceramic (IEC Approved)
3.1.2 For 110V operation: 120V 3.15A Slow Blow (UL Approved)

PBX5000

3.1.3 For 240V operation: 250V T2A Slow Blow Ceramic (IEC Approved)
3.1.4 For 110V operation: 120V 3.15A Slow Blow (UL Approved)

3.2 Fuse Replacement

3.2.1 The Fuse located in the removable drawer in the mains inlet connector



CAUTION!

To reduce the risk of fire replace fuse only with the same type and rating. Never use a mended fuse! Do not short circuit the fuse holder!

4 Primary Disconnect Device

The Plug/Appliance coupler (Power Lead) is the Primary Disconnect device, this lead must be readily accessible at all times.

Any approved cord set can be used (BASEC, HAR, UL etc) provided it meets the appropriate current carrying capability.

5 Rack Removal

5.1 When installing the racks, fit the carrier frame to the 19inch main rack first. Then fit the Workstation and Interface racks.

CAUTION! These racks are heavy and long, it may be advisable to have help when sliding in to the carrier.

5.2 During service, one or other of the racks may need to be pulled forward to allow access to the rear removable lid. Caution should be taken as the weight may make the unit unstable.

5.3 The Lids to both units must be fitted at all times, unless they are being serviced.



6 Servicing

6.1 Refer to Installation manual before removing lids.

6.2 There are rotating blades (fans) enclosed within the units, care must be taken after opening the lids that loose clothing, hair, etc. does not get entangled.

CAUTION!

Switch off power before removing or inserting printed circuit boards and connectors!



7 Ventilation

7.1a The PBX6001 and PBX6002 cabinets are cooled by a ventilation system.

Air is drawn in through the front of the rack and is expelled at the rear left hand side.

7.1b In the PBX5000 Control Panel air is drawn in under the control panels and expelled at the back. For this reason, make sure that the air inlets are not covered when setting up and that sufficient space is maintained to the other units.

7.2 For cooling reasons always keep the covers closed during operation.

7.3 The admissible ambient temperature range of the Pogle Colour Digital Correction system is from +5C (41 F) to +30C (86 F). It is however strongly recommended to not exceed an ambient temperature of 25C (77F).

7.4 Make sure that the machine is protected against high humidity!

7.5 Make sure that enough space is provided so that the cabinets are easily accessible for operation and service works.



The Pogle Colour Correction System is designed according to regulations of the Underwriters Laboratories Inc. Northbrook, Illinois, USA, certificated and registered under file no E151692.

LISTED PROFESSIONAL
VIDEO EQUIPMENT
4Z99



Conforms with the following European directives and CE marked:
Safety 73/23/EEC Low voltage directives EN 60950/ 1997
EMC/ EMI 89/336/EEC, EN 55103-1/ 1996, EN 55103-2/ 1996

Application

The Pogle Telecine Control System is designed for application in TV studios only.

For safety reasons, any application for purposes other than the original intended is not allowed.

FCC Rules

This equipment has been tested and found to comply with the limits for a Class A digital device, pursuant to the part 15 of the FCC Rules. These limits are designed to provide reasonable protection against harmful interference when the equipment is operated in a commercial environment.

This equipment generates, uses, and can radiate radio frequency energy and, if not installed and used in accordance with the instruction manual, may cause harmful interference to radio communications.

Operation of this equipment in a residential area is likely to cause harmful interference in which case the user will be required to correct the interference at their own expense.

Unit Functional Description

The **Pogle Platinum** consists of four main parts, one of which is an SGI Computer....

1] PBX6001 Pogle Workstation

This is a 2U high 19" Rack unit which contains a powerful computer workstation based around twin Motorola 32bit Microprocessors.

The workstation is the control centre for the Pogle system, commands are collected from the control panel interface interpreted by the appropriate software handler and then passed on to either the telecine interface rack or via serial interconnections to any VTR's or other devices connected to the system.

One of the microprocessors within the workstation is dedicated to handling commands from the user. This device is coupled to a co-processor which manages the high resolution VDU display.

A dual ported ram buffer is used to link to another microprocessor which is responsible for handling all of the input/output resources with which the POGLE workstation is equipped.

The Pogle workstation runs a real time multi-tasking operating system which allows several system tasks to run at the same time. Extensive use is made of the interrupt handling facilities of the 68020 microprocessor to ensure that software handlers respond rapidly to real time events especially with relation to television sync pulses.

The first SCSI port was used on Andix systems to drive the Hard Disk drive that stored the system software and user created data files. This is now done via the SGI Indy or O2. On power-up the system software is down loaded from the SGI unit and passed on to all of the microprocessors within Pogle.

The software files on the SGI may be easily updated by means of downloading files from the web site or via a CD. This allows all new software updates to be installed onto the system simply by downloading the appropriate software version thus it is rarely necessary for the user to have to open the electronics racks and exchange Eproms or other components in order to effect a software update.

The second SCSI port is used to communicate to other units within the Pogle system such as the Telecine Interface Rack.

Pogle Platinum

Pogle Platinum features an enhanced Graphical User Interface [GUI] which is built around a Silicon graphics Computer [SGI] either an Indy or an O2.

Note that the SGI computer is not usually supplied by Pandora. Instead it should be ordered from the local Silicon Graphics representative to ensure full service and maintenance support.

Information for ordering the SGI computer can be found on our web site

<http://pogle.pandora-int.com>

When configured for POGLE Platinum the Hard Disk Unit is removed from the workstation rack and the SGI computer is connected instead using the SCSI interface. This provides a reliable high bandwidth connection for communication between the microprocessor in the SGI and the microprocessor within the Pogle. As before all software for Pogle is downloaded from the hard disk except that now this is inside the SGI computer. Software for the Pogle Platinum can be downloaded from our web site or if requested from a CD ROM supplied by Pandora. Note however that the Pogle workstation carries a unique serial number and software will only run on licensed systems.

NOTE: Indy and O2 are trademarks of Silicon Graphics Inc.

The Graphical User Interface is driven entirely from the SGI running under the standard Irix operating system. All real time tasks however are controlled from the Pogle workstation rack with its proven real time software. Note that as a SCSI interface is used the SGI computer must be mounted close to the

PBX6001 rack [normally directly above]. Longer cables can be used to connect the SGI to the control desk and monitor.

2] PBX6002 Pogle Telecine Interface

This is also a 2U high 19" rack unit which must be mounted adjacent to the Pogle Workstation rack in the special carrier frame provided.

This rack converts the SCSI commands issued by the Pogle Workstation into the required format to control whatever telecine system is attached. Another Motorola 68k microprocessor is used to control this process.

The combination of hardware contained within this rack varies depending on the type of telecine interface required. Please see the relevant section of this manual for details concerning your telecine system.

Sometimes the Pogle system is supplied as a Tape to Tape controller. In this case the PBX6002 interface rack is not required as there is no telecine to interface.

3] PBX5000 Pogle Control Panel Interface

The PBX5000 is a Motorola 68030 based subsystem which scans the many control switches and encoders of the Pogle system and converts these into a digital code which is then transmitted to the main Pogle Workstation and also the SGI workstation [if used] via a high speed RS422 data link.

The control panel may be supplied in two versions either in a self-contained moulded enclosure or as a desk build kit which includes a polished wooden mounting frame and a kit of parts to enable the panels to be fitted into a custom made desk.

If the moulded enclosure is used then all that will be required is a power cable and a standard 9-pin RS422 cable to connect to the Pogle system. Normally a 10 metre cable is supplied but this can be easily extended if required.

The desk kit is a little more complicated in that space will have to be allocated directly beneath [or behind] the control panels to mount the control rack. This rack connects to the panels via ribbon cables which cannot be extended.

Pogle Platinum ...

Although it is not required for normal operation of Pogle software many users choose to extend the SGI keyboard cable in to the control room to allow easy access to SGI related functions such as file back up or to download new software via the network. We have found cable runs up to 20 or 30 meters usually present no problems. It is not so necessary to extend the SGI mouse as the mouse function can be driven directly from the Pogle Control desk or the optional Wacom Graphic tablet.

Equipment Location

There are many factors affecting the way that the Pogle Control system is installed. The system is fairly flexible and can be adapted to many environments but there are a few constraints which determine where the various pieces can go.....

Cables that can NOT be extended

SCSI Bus

1] Between the SGI Computer and the PBX6001 Pogle Workstation Rack

2] Between the PBX6001 Workstation Rack and the PBX6002 Telecine Interface Rack.

The SCSI bus communication is very critical to the operation of the system. Normally we expect the two Pogle racks to be mounted in adjacent rack positions [we supply a mounting frame to facilitate this] and the SGI computer to be less than 1 Meter away. The SGI SCSI connection can be extended a little, sometimes necessary if the customer wishes to add a JAZZ drive or similar for file backup, other than this it is generally preferable to keep everything as close as possible.

Control Panel Ribbon Cables

This is not an issue when using the moulded control desk as everything is mounted inside. When using the wooden frame desk mounting kit however it is essential that space is found for the control electronics enclosure directly below or behind the panels.

Analogue Telecine Connections

Modern telecine's usually have digital control lines and so this restriction does not apply but for older machines such as Cintel MkIII or BTS Quadra most of the controls are DC voltages.

Standard cable lengths supplied by Pandora are usually 4 Meters. Other lengths can be supplied to special order but in general the Telecine machine MUST be less than 10 meters from the PBX6002 rack or else there may be problems with noise.

Cables that can be extended easily

RS422

This includes the Connection between the PBX5000 control desk and the PBX6001 Pogle Workstation Rack. Also Video Tape Recorders and other remotely controlled devices.

Normally we supply 10 meter cables but it is possible to supply longer lengths to order.

Some telecines and also the Pandora PIXI colour corrector also use RS422 connections but be aware that some of these connections run at VERY high speeds and so there are some restrictions on the cable length. In general if you need to extend RS422 cables over about 10 Meters then care must be taken with the choice of cable used and its construction, low capacitance, individually shielded pairs are absolutely necessary to avoid cross-talk and other interference problems. Please contact Pandora for advice.

RGB Video to SGI Monitor

Normally the SGI Video Monitor uses an RGB connection with Sync on Green Channel. O2's are equipped with a 15pin Mini DEE connector whilst INDY's use the more robust 13W3 connections [looks like a 25way Dee Type but with 3 coax pins built in].

In either case Pandora supply adaptors so that the bulk of the cable length consists of three standard 75ohm BNC cables for RGB.

SGI Keyboard & Mouse Cables

Extension cables may be ordered to extend these devices up to 20 or 30 meters.

Ethernet

Many newer telecine machines use Ethernet connections for control. These should NOT be connected to the house network as heavy traffic could interrupt the control to the telecine.

In the Pogle system a dedicated Ethernet is provided between the PBX6002 telecine interface rack and the machine. The SGI Ethernet is available for regular networking e.g. between rooms although we recommend that this be connected to the house network through an Ethernet switch.

General Recommendations

All of this means that for a standard installation we recommend the all of the Pogle equipment with the exception of the control panel should be mounted in a 19" rack bay as close as possible to the telecine machine. The control panel and SGI Monitor can be mounted some distance away in the control room. If there are any special requirements or constraints on a particular installation please contact Pandora at the earliest opportunity to discuss the possible complications.

Email: service@pandora-int.com



Please note the Pogle Telecine Control System only conforms to UL and CE regulations as long as it is installed in the recommended way and with standard cable sets supplied by Pandora International Limited.

In case the customer requests that the system be installed in any other way then the CE and UL labelling **must** be removed.

Pandora International Limited will not be responsible for any operational and potential safety problems caused when the system is installed in any way other than recommended by Pandora International Limited. Or when there have been modifications to the system after the date of installation.

Equipment Dimensions

Pogle Workstation and Telecine Interface Racks [Side View]

Each rack occupies 2U of space in a standard 19 inch rack bay.

A special carrying frame [4U] is provided which supports the racks from the front and allows them to be slid forward for service. Care must be taken when running cables to the rear of each rack to provide sufficient slack to allow the necessary forward movement of each rack.

We recommend that at least a 1U gap be left above the top most rack [usually the PBX6002] to allow unrestricted airflow and free movement of the rack.

Normally a rack shelf would be installed at this position to mount the SGI Indy or O2 computer.

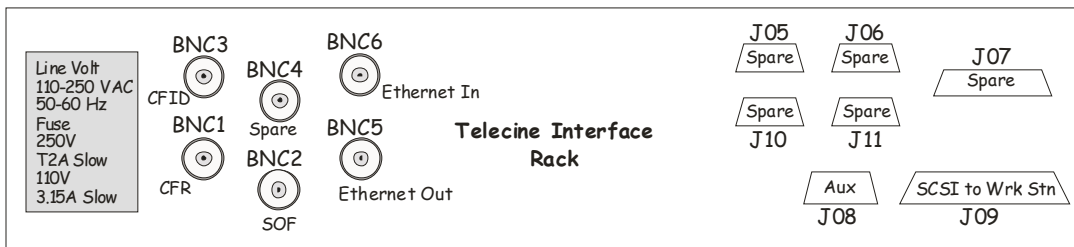
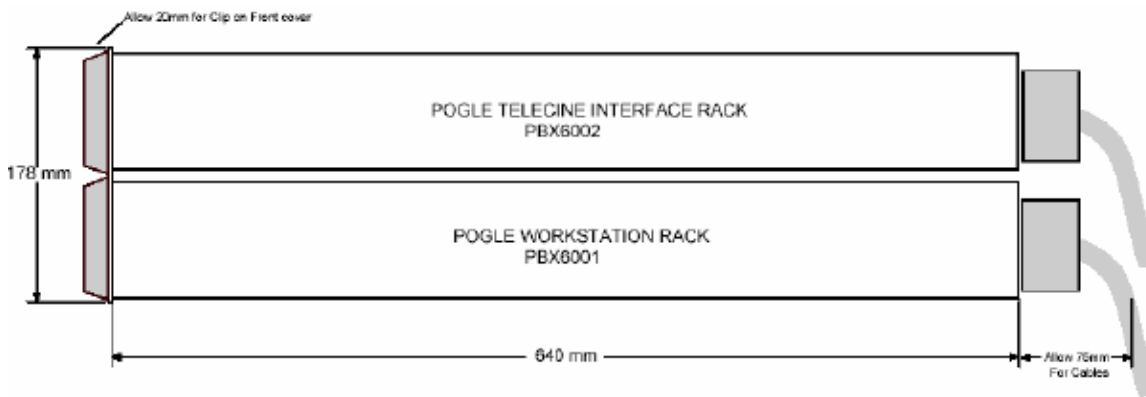

Telecine Interface rack PBX 6002

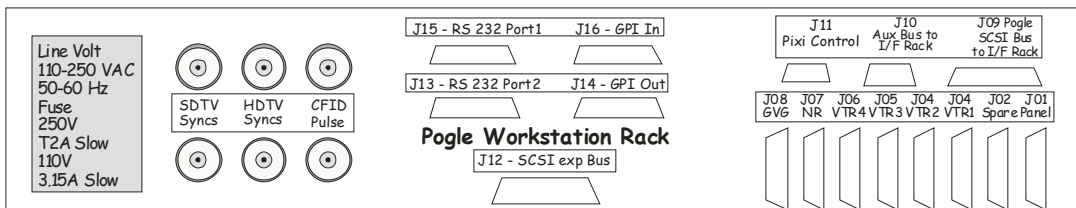

Pogle Workstation rack PBX 6001

Option 1 - "Moulded Console"

Panels mounted within moulded Frame.
This is designed to be mounted on a control desk, with a location / base tray hole cut into the desk.
Finish is Nextel B21

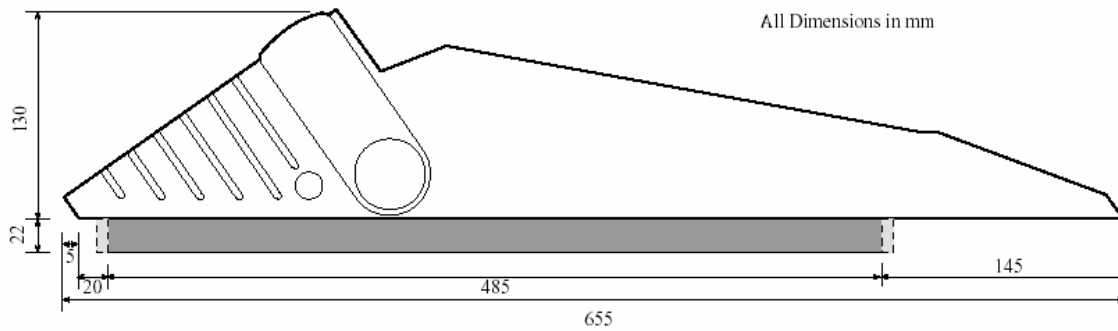
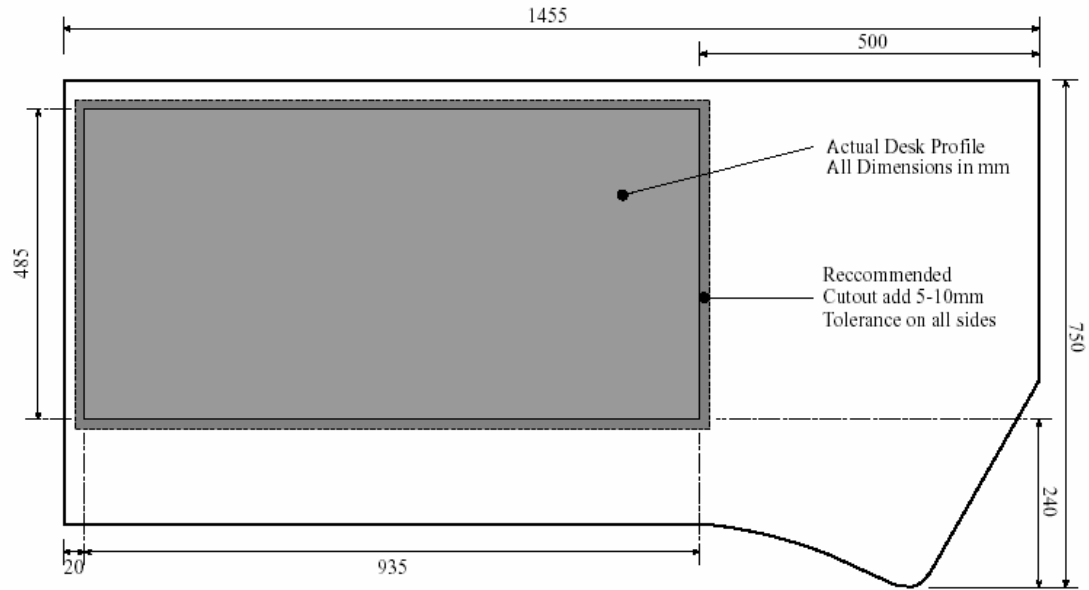

Moulded Console Side View

Option 2 - "Picture Frame"

Panels mounted within wooden "Picture Frame".
This is designed to be cut into an existing wooden control desk.
Finish is natural polished cherry.

N.B. - The electronics enclosure and floppy disk drive units must be mounted separately with this option. See separate sheets.

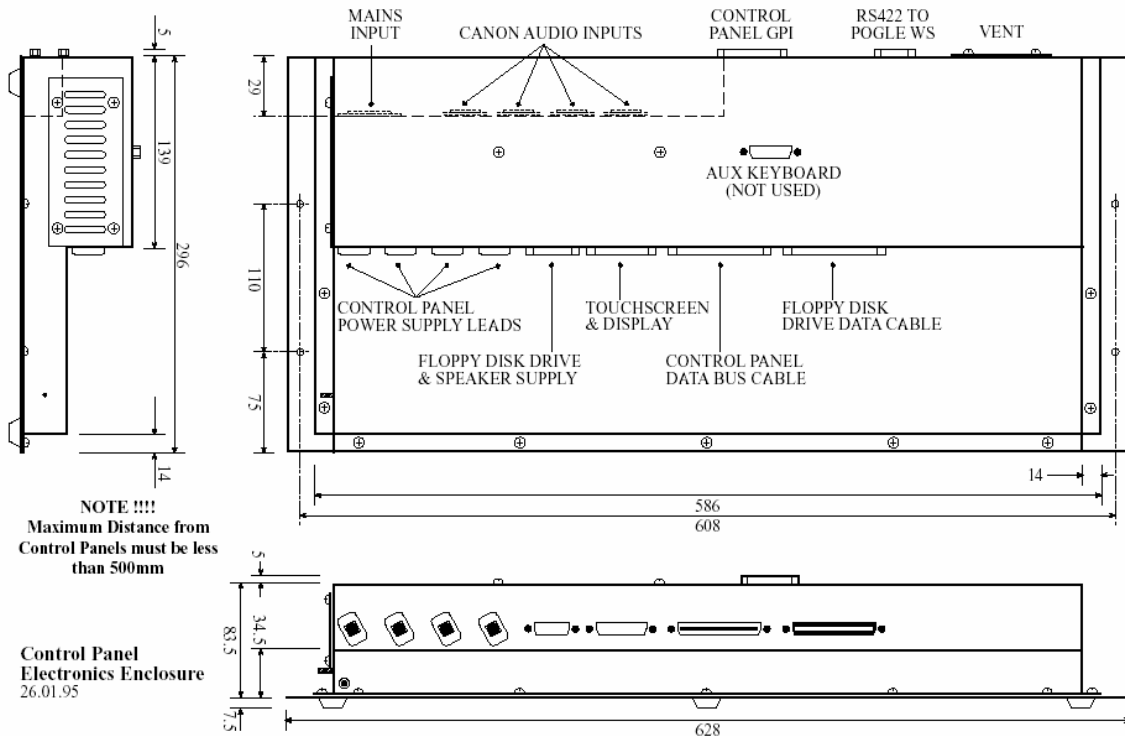
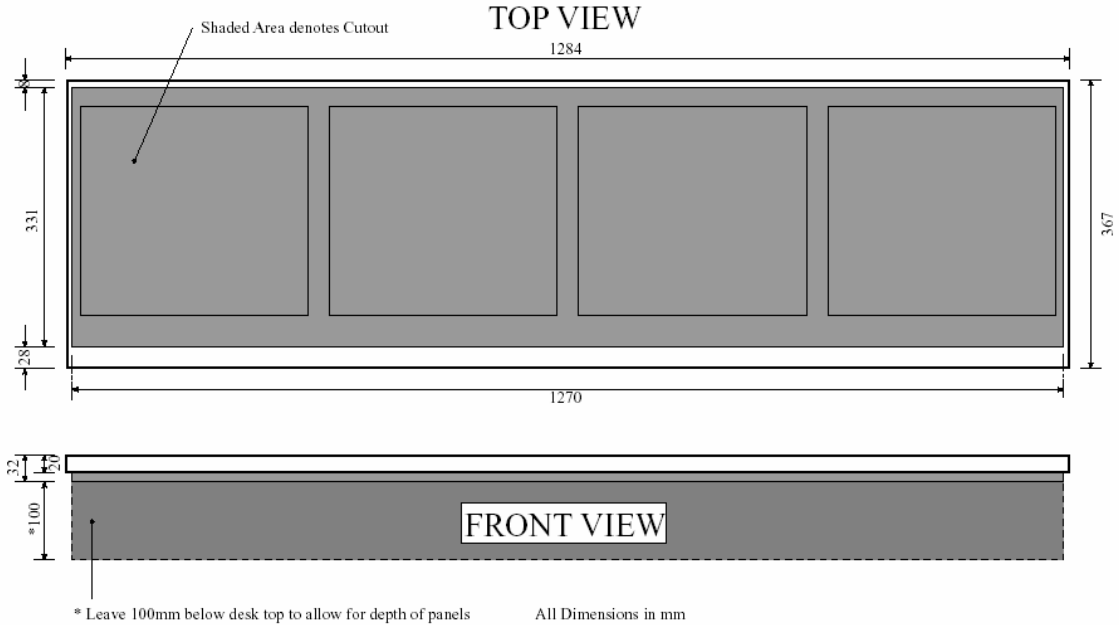

Pogle Installation – General

1] Rack Mounting

It is first necessary to mount the two electronics racks.

The **Pogle Workstation** and **Pogle Telecine Interface** are mounted in a special carrier frame in a convenient position close to the telecine. Normally 4m length cables are supplied to connect to the telecine - it is not advisable to extend these as there is a possibility of picking up noise or interference

The carrier frame provides not only support for the extended depth of these racks but also a means by which either rack may be slid forward for service and routine maintenance. This is important as POGLE does not use a card frame system and each rack contains a single large PCB which may only be accessed from the top of the enclosure.

Note:

The Pogle Workstation Rack PBX6001 must be mounted into the bottom position of the Carrier Frame. If this is not observed then it will be impossible to access the Telecine Interface Rack after cables have been connected.

Cables must be dressed in such a way as to allow sufficient movement for the racks to be slid forward. The Pogle Workstation Rack may be slid forward on its own in order for work to be carried out. In order for the Telecine Interface Rack to be slid forward it is also necessary to pull forward the Pogle Workstation unit which then provides additional support for the Telecine Interface Rack. To provide the best service access to the Pogle electronics it is better not to mount any other equipment directly above in the rack, a 1U blanking panel is recommended. Please take care when sliding rack's forward that the equipment rack does not become unbalanced and fall over.

Each of the two main Pogle racks are equipped with fans which pull in fresh air from a grill at the front of the rack and expel it along the left hand side [when viewed from the front]. Provision should be made when mounting the units to allow some air circulation around the sides of the racks.

It should be emphasised that the proximity of these racks to the telecine is important especially in the case of analogue machines. As the signals carried by the various multicore cables between Pogle and the telecine are prone to noise pickup and hum their length should be kept as short as possible.

The Pogle control panel can be mounted some distance away from the main electronics racks. The only connection between is an RS422 cable normally 10 metres long but which can be easily extended.

2] Mains Power Wiring

Each of the Pogle racks requires mains power on a standard IEC type mains connector. Suitable connectors are supplied with the system.

Note power requirements are as follows....

PBX6001 + PBX6002

Line Voltage : 100-250VAC @ 50/60Hz
Auto Range Sensing by Power Supply Unit.
Line Current : 1A Max @ 240V
VA Rating : 110VA @ 110V, 140VA @ 240V

PBX5000

Line Voltage : 100-110VAC @ 60Hz
220-240VAC @ 50Hz
Manual Voltage Selection by Internal Link.
Line Current : 1A Max @ 240V
VA Rating : 110VA @ 110V, 140VA @ 240V

Note.

Make sure that the VOLTAGE SELECT on PBX5000 [Control Panel] is correctly configured for the supply. Permanent damage will be caused if the wrong voltage is connected.

The SGI Computer and VDU monitor also require mains power and are normally supplied with a cable for this purpose. Please consult the relevant documentation supplied from SGI.

As with all computer systems it is important that the power supplied to the system is well regulated and noise free - interference may cause data corruption and in serious cases the computer may crash causing the operator to lose control of the telecine.

Preferably the VDU monitor should be driven from the same supply as the computer rack or at least the same phase.

All units should be connected to a good technical ground. This is especially important in the case of the Telecine Interface rack as any noise on the system ground will eventually appear as hum on the control voltages fed to the telecine. A special earth terminal is fitted to this rack which may be used to link the system directly to the telecine chassis using heavy gauge wire if noise problems are apparent.

3] Pogle Inter-Rack Connections

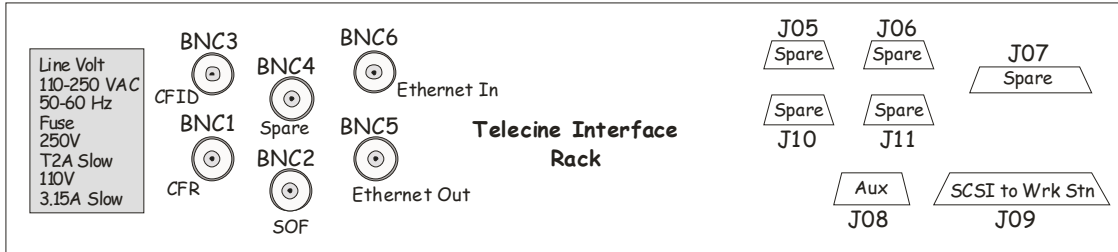

Telecine Interface rack PBX 6002

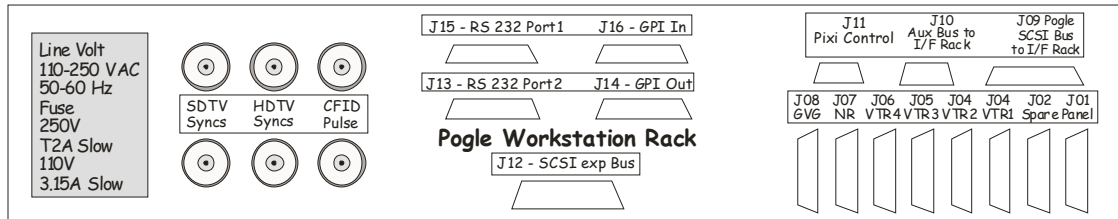

Pogle Workstation rack PBX 6001

Two cables are supplied with the system to interconnect the **Pogle Workstation** with the **Pogle Telecine Interface Racks**.

The first of these is a 50 way ribbon equipped with CENTRONIC type connectors; this carries the SCSI BUS connection between the two racks.

The second is a 15 way male dee to dee ribbon cable which carries various timing pulses and signals.

PBX6001	PBX6002	
J09	J09	50 Way SCSI Bus
J10	J08	15 Way Aux Bus

4] Pogle Workstation to SGI Computer

The SCSI port of the SGI Computer must be connected to J12 [SCSI Expansion Bus] on the rear of the PBX6001 rack. Pandora supply the necessary adaptor cables for this but note that different cables are required for Indy and O2 so the correct type must be specified at the time of ordering!!

If required Optional Removable Storage Drives may also be connected in series with the SCSI interface. E.g. for an Indy a CD Rom drive may be required or perhaps a JAZZ or ZIP drive for file backup.

In all cases the following rules apply

#1] The **Pogle Workstation** rack will be SCSI ID#3 and this cannot be changed. Make sure that the ID setting of any additional drive does not conflict with this.

- #2] The Pogle Workstation **MUST BE** the last device on the SCSI chain i.e. furthest down the cable from the SGI workstation. Ensure that **SCSI termination** is **DISABLED** on any additional devices.
- #3] Keep the SCSI cables as short as possible.

In some cases a SCSI mounted floppy drive may be required in order to read EDL's etc. In this case the Floppy drive will have to be mounted in the equipment room rather than the control desk. If it is important for the operator to have a floppy drive available locally we recommend that a low cost PC [even a laptop] to be installed into the equipment room, this can then be connected via Ethernet to the SGI which can then be any distance away. Data can easily be transferred over the network using FTP or NFS.

Visit our web site for the latest information:- <http://pogle.pandora-int.com/>

5] Pogle Workstation Rack to Pogle Control Panel Interface

A single RS422 cable of length 10 Metres is supplied with the system, it is possible to order a greater length if required.

Connection is from the rear of the **Pogle Workstation Rack J01** to the rear of the **Pogle Control Panel Interface Rack J01**.

On Pogle Platinum systems an adapter cable is supplied to allow the control panel RS422 to also connect to the SGI computer where it should be attached to Serial Port #2.

If the SGI computer is an O2 it only supports RS232 communication and so an additional adaptor is supplied to perform the conversion.

6] GUI - Graphical User Interface

A connection will be required to the Computer Monitor in the control room for the Graphical User Interface. On older [**Andix**] **Systems** this was driven directly from the three BNC connectors on the rear of the Pogle Workstation Rack. On newer **Pogle Platinum** systems however these BNC's are used for other purposes and the monitor is driven directly from the SGI computer. O2 computers are fitted with a 15pin HD Connector [similar to the type found on most standard PC's] Indy's are equipped with a 13V3 connector [looks rather like a 25 way Dee type but with three Coax inserts replacing some of the pins].

In both cases Pandora supply a suitable adaptor box that converts the Monitor Connection from the SGI to three standard 75 ohm BNC cables. Video Information is transmitted as RGB with Sync on Green Channel. A similar box is provided to connect to the monitor at the other end although some monitors are already equipped with BNC inputs and these should be used where available. Please refer to our web site for a discussion on the type of monitor that should be used as there are many options for SGI.

Note that there are also some LCD flat screen displays available for SGI. Some of these use standard video connections however there are a few which provide a ribbon cable between the screen and a special interface card within the O2. In general this type should be avoided as they compromise the correct placement of the Pogle and SGI equipment — normally the SGI computer is mounted some distance away from the control room as it has to be connected directly to the Pogle Workstation Rack.

7] Control Panel Wiring

There are two options for mounting the new control consoles into a desk...
The normal option is the plastic moulded surround which is a completely self contained unit housing the power supply in addition to the actual control panels.

To special order a polished wooden surround is available which enables the panels to be built into an existing desk. In this case the power supply electronics must be mounted as a separate unit within the desk.

Both options require a simple rectangular cut-out into the control surface as detailed in the diagrams on the following pages.

The control panels may be mounted into either housing in any order.

Two sets of cables are supplied.....

Power cables - four of these [one for each panel] emerge from the main electronics rack. These are all identical and may be plugged into the panels in any convenient order.

Data Cable - this is a fifty way ribbon which daisy chains between the panels.

Again the order is unimportant.

The central connector on this cable mates with a 50 way header on the main electronics rack.

Take great care when installing or removing ribbon cables as it is quite easy to either bend the pins or to tear the ribbon cable from the back of the connector!!

Electroluminescent Display [Yellow]

The display on the DCP control panel has an additional ribbon cable which connects directly to a 25 way Dee connector on the main electronics rack.

The connector on the display is mounted on the bottom centre of the display panel and is keyed to ensure correct insertion.

CAUTION!

We recommend that power is switched off before installing this cable as it is possible to permanently damage the display.

Panel Reset

The control panel is equipped with a reset button which is mounted on the front edge of the electronics rack.

A reset can also be effected by holding down the two ENTER keys [one on the operations panel the other on the transport panel] together with the STOP key.

Note that this does **NOT** reset the **POGLE** just the **Control Panel**.

After reset the message **Loading New Software** should appear on the fluorescent display and there will be a short pause whilst the software uploads from the system hard disk. Obviously the Pogle Workstation and SGI computer need to be running in order to complete this process.

Earth Connection

On the back of each Panel there is an Earth Tag. These must be linked via the cable supplied to the chassis of the electronics enclosure.

This connection is particularly important when the panels are mounted into a wooden desk and in areas where static electricity may be a problem. We recommend that all wooden desks are constructed with a base panel between the bottom of the panels and the floor, if possible a metal shielding plate should also be installed.

All precautions should be taken against Static discharge as this can cause permanent damage to the Panel electronics as well as annoying interruptions to the normal operation of Pogle.

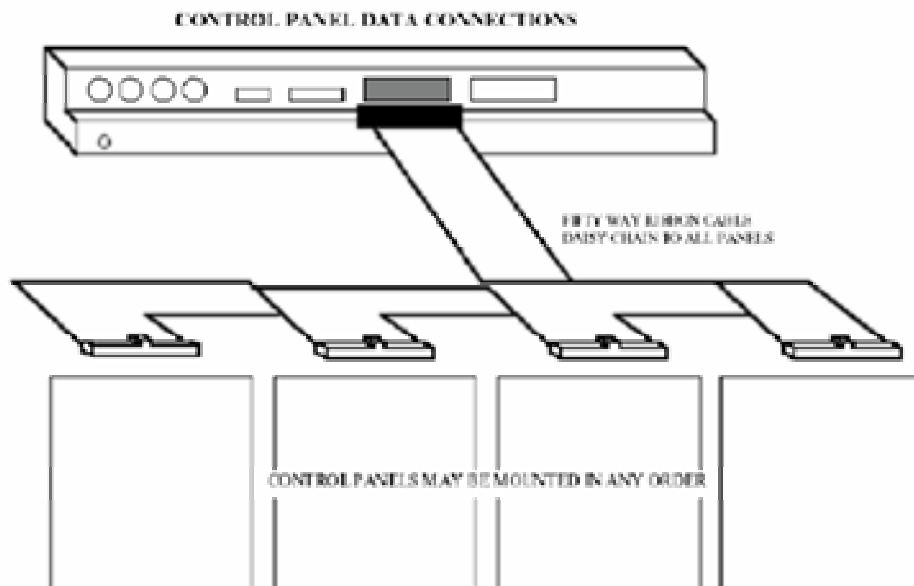
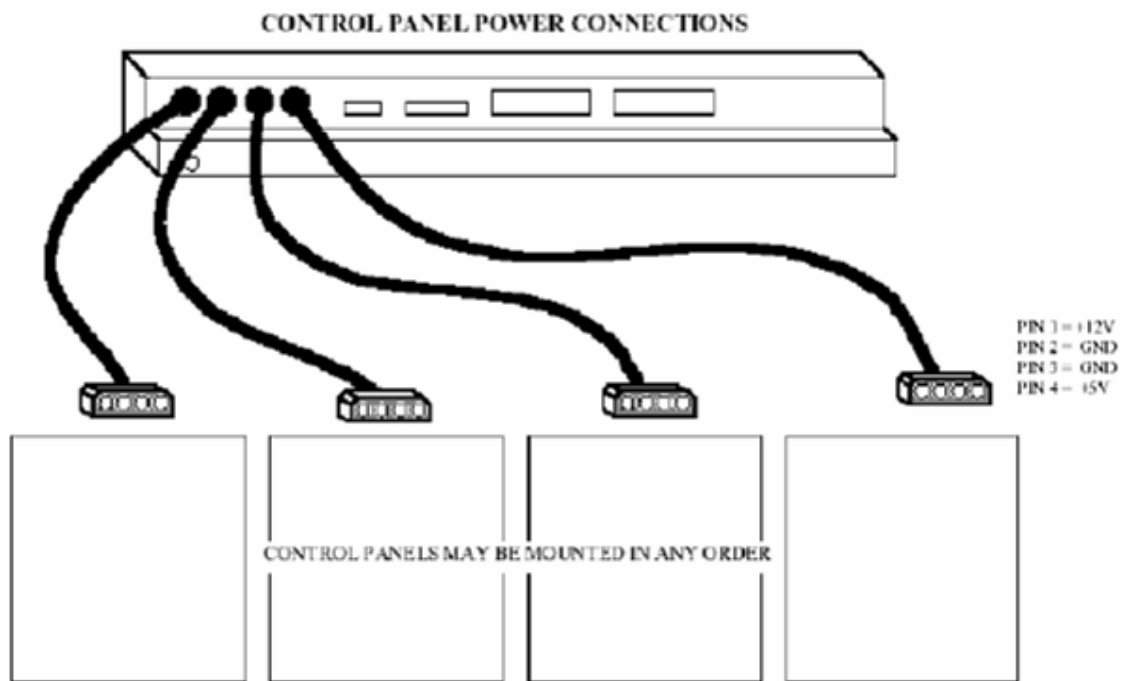

8] System Sync Pulses

Two signals must be provided from the main System Pulse Generator. POGLE will **NOT** operate without the correct sync signals connected.

a] **Black + Burst** [or Mixed Syncs]

Required by the main Workstation Rack. This signal is used to time all communication between POGLE and other devices within the telecine suite and is crucial for correct operation. A high impedance loop-thru connection is provided on standard 75connectors [J23-24 PBX6011 rack].

It is obviously important that this signal should be obtained either from the same source or from a correctly timed derivative of the reference signal used to drive both the Telecine and any VTR's attached to POGLE.

Newer Pogle systems are also equipped with a separate input for HDTV [tri-level] sync. [An update kit can be ordered for older racks].

Pogle software can select between the two inputs as required.

Note that it is not always necessary to have a separate connection for HDTV sync when working in a multi-standard environment. Spirit Telecine's provide a SDTV reference sync at all times even when working in HDTV modes and this can be used to drive Pogle Directly.

There are now some dual standard pulse generators that provide both HDTV and 525/625 syncs locked together.

b] **Field 1 Ident [CfiD]**

This signal is used only when controlling SDTV VTR's.

If the VTR control option is not fitted then this signal is not required.

This pulse is used by the Pogle's Internal Colour Framer to ensure that edits are performed with correct timing when using PAL or NTSC composite recorders.

When running in PAL format this pulse marks the first field of an 8 field sequence.

In NTSC the pulse occurs after every 4 fields.

Some Pulse Generators output this pulse as a narrow [1 line wide] pulse during field one others provide a square wave. Either type may be used as the input to POGLE is edge triggered.

Another form of this pulse is a narrow white pulse superimposed on a black signal with normal syncs etc. It is possible to use this type of pulse as well but the input threshold level of POGLE will need to be set carefully.

Connection usually should be made via a 75 ohm cable to BNC 3 on the rear of the **Telecine Interface Rack**. It will then be necessary to adjust the input threshold level as described in the section **Timing Pulse Adjustment** on the following page of this manual.

If there is no **Telecine Interface** [i.e. Tape to Tape System] then an alternative input for CfiD will be provided on the rear of the **PBX6001 Workstation Rack**.

Open the SOURCE SETUP window on the Pogle Platinum display to show the correct operation of the system sync signals. The Vertical frequency of attached sync signals is displayed.

Other pulse inputs are specific to the Telecine type in use.

Please see the relevant section of this manual for details.

Timing Pulse Adjustment for Telecine Interface rack PBX6002

Within the **Telecine Interface Rack** all timing pulses are taken into the PBX6021 board [or newer PBX6121 board] where they are buffered by an LM301 op-amp

The second input of each is connected to a pot making a simple comparator circuit. The level of the comparator can be adjusted by the pot thereby allowing these inputs to be setup for a wide range of pulse levels.

Remove the lid from the Telecine interface rack to gain access to the pots.....

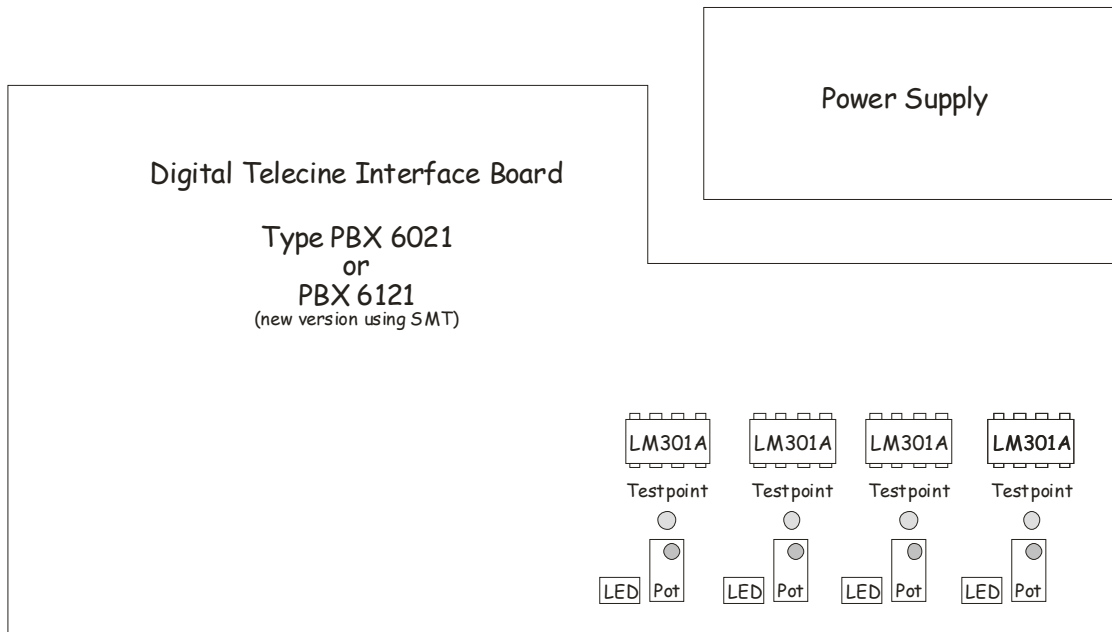

Adjust Pot until the associated LED flashes at the correct rate. Use a scope to observe the resultant pulses on the test points. These should be at TTL levels.

CINTEL TELECINE's [MkIII / Turbo I / Turbo II / URSA / URSA GOLD]

INPUT 1 [RP1] **TK FRAME PULSE** from digiscan rack film frame rate square wave

INPUT 2 [RP2] **WRITE VERTICAL DRIVE** from digiscan rack film frame rate pulse

INPUT 3 [RP3] **COLOUR FIELD IDENT** from system pulse gen 6.25 Hz PAL 15 Hz NTSC

INPUT 4 [RP4] NOT USED

BTS TELECINE's [FDL60 / FDL90 / QUADRA]

INPUT 1 [RP1] **FRID** from J34 via special cable [supplied] only runs when transport moving

INPUT 2 [RP2] **FRI** from J34 via special cable [supplied] only runs when transport moving

INPUT 3 [RP3] **COLOUR FIELD IDENT** from system pulse gen 6.25 Hz PAL 15 Hz NTSC

INPUT 4 [RP4] **CFR OUT** from FDL frame store 6Hz

Other Telecines to follow

RS422 Cables

Pogle uses standard RS422 9 pin "D" type cables for the control of VTR's, Noise Reducers, Switchers and the Control Panel.

Note that Pandora only supplies 1 RS422 cable (10 meters) for the interconnection between the **Workstation** and the **Control Panel**. Additional cables in other lengths may be ordered
In the case of Ursa, Pandora also supplies 2 x 5 meter cables for the FAST and E.S. bus.

The RS422 interface uses two twisted pairs each with an individual screen.

These are connected as follows.....

2 + 7 First Pair

4 Ground for first pair

3 + 8 Second Pair

6 Ground for second pair

Cintel Ursa Series Interface

Includes Ursa Gold and Ursa Diamond.

A total of five cables are required as detailed below.....

A] ES-Bus

This is a 9 pin dee to 9 pin dee cable normally supplied with **Pogle**.

Connection is from the **Pogle Telecine Interface Rack J05** to the **ES Bus 1** connector on the rear of the Ursa Frame Store which is the Rack (or Ursa Gold/ Diamond a Termination Panel) mounted on the bottom left of the telecine when viewed from the rear.

B] Fast Bus

This is an identical 9 pin dee to 9 pin dee cable as used for the ES Bus connection. The routing is similar from the rear of the **Pogle Telecine Interface Rack J06** to the Ursa Frame Store Rack/ Termination Panel.

NOTE: Although the ES + Fast Buses Use Standard 9 Pin Connectors the pin out is NOT standard.

C] Counter Pulses

A special adaptor pod is supplied with Pogle this connects to BPL5 on the rear of the Ursa servo rack which is on the right hand side of the machine [above the linear scan amplifiers] when viewed from the rear of the telecine. On Ursa Gold/ Diamond this will be found on the Termination Panel to the right hand side of the Telecine when viewed from the rear.

BPL5 is a seven pin DIN socket originally intended to provide pulses to a FERRIT sound follower. Note that the Pogle buffer pod is equipped with an output socket into which a Ferrit may be connected if required.

The output of the buffer pod is connected to a 25 way dee type connector on the rear of the **Pogle Telecine Interface**.

D] Telecine Frame Pulse

This connection is made via a 75 Ω BNC lead from the marked socket on the rear of the **Telecine Frame Store**. [lower right hand rack when viewed from the rear; Ursa **Gold/ Diamond Termination Panel** to the right hand side when viewed from the rear] to the first of the group on BNC sockets on the **Pogle Telecine Interface Rack**.

E] Write Vertical Drive Pulse

This connection is made via a 75 Ω BNC lead from the marked socket on the rear of the **Telecine Frame Store/ Termination Panel**. Note that this socket is normally in use and so a BNC Tee piece will be required. Connection is made to the second of the group of BNC sockets on the rear of the **Pogle Telecine Interface Rack**.

Ready made cables of 4 Metre length are normally supplied with POGLE for connections a, b, and c above. The wiring for these connectors is shown in this manual and it is possible to order additional lengths.

All BNC cables are supplied by the user and should be made to length as part of the installation procedure.

Basic Interconnections Pogle to Cintel Ursa series

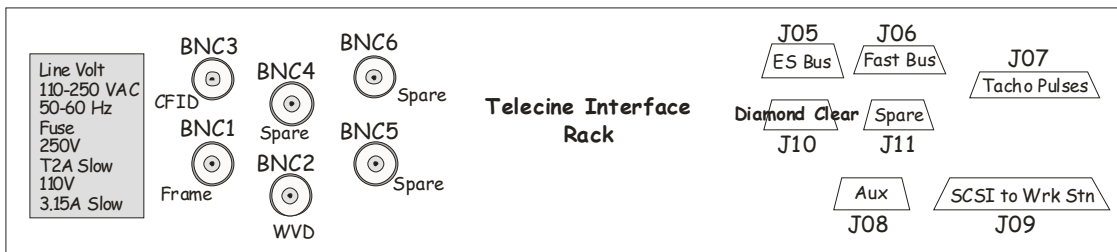
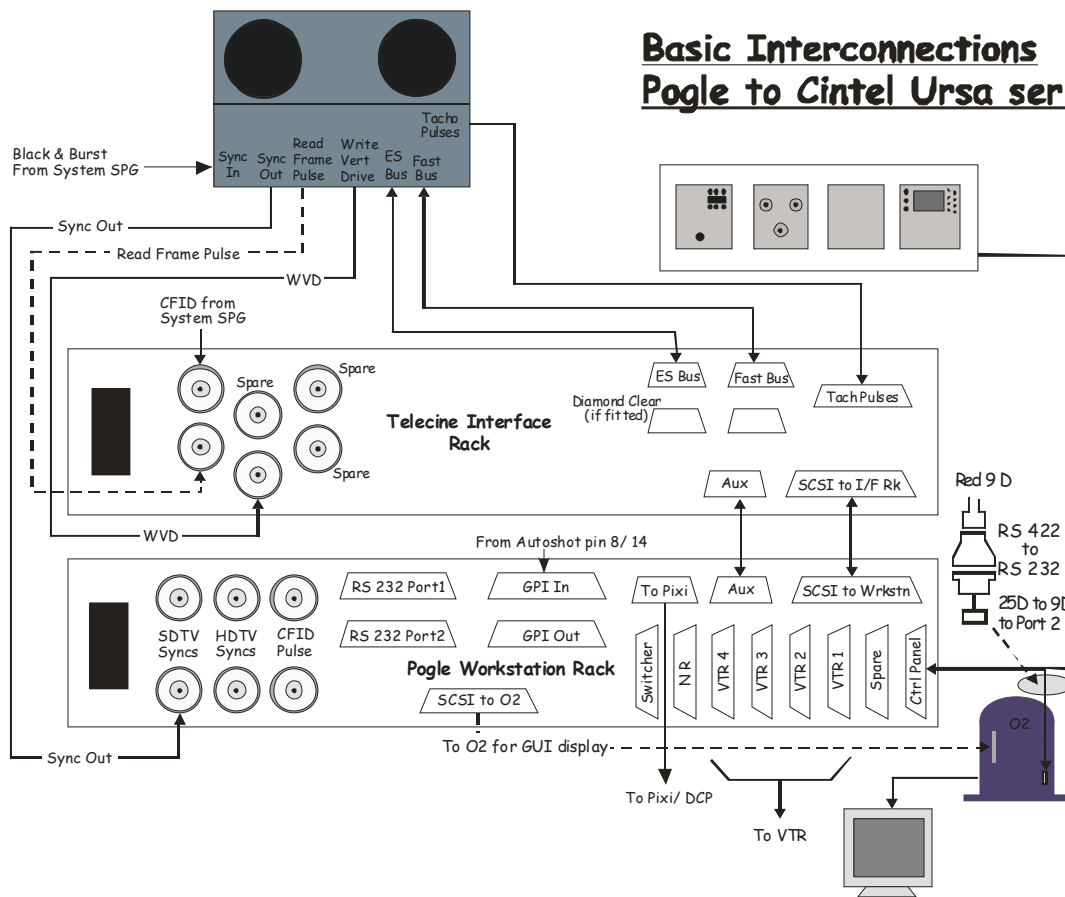

Telecine Interface Rack PBX 6002

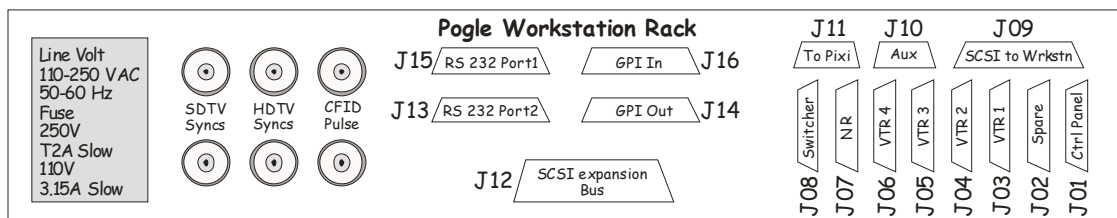

Pogle Workstation Rack PBX 6001

Cintel C-Reality & Rascal Interface

The C-Reality & Rascal Telecine's are controlled via an Ethernet connection. This is driven from a special Ethernet port on the Pogle Telecine Interface Rack.

Note that the POGLE is equipped with a 10base2 [50 Ω BNC] Ethernet connection whilst the Telecine may have a 10baseT [UTP] type connection. For C-Reality interfaces Pandora usually supply an Ethernet hub equipped with a 10base2 port. This can be swapped with the Ethernet hub which is mounted inside the back of C-Reality or alternatively it can just be linked to it using an RJ45 type [UTP] Ethernet connector.

Important notes for 10base2 Ethernet.

This connection is made using 50 Ω cables and connectors, 75 Ω video cables and fittings WILL NOT WORK. Pandora supplies the necessary cables and terminations.

The 10base2 connection must be terminated at each end of the cable using a 50 Ω terminator. At the Pogle end there are two BNC sockets [loop thru]. A 50 Ω terminator is installed on one socket whilst the other connects to the special 50 Ω cable that goes to the Ethernet hub inside C-Reality.

Some types of Ethernet hub are equipped with a termination switch. If this type is provided please ensure that the 50 Ω TERM switch is in the ON position. If the Ethernet hub does not have internal termination then it will be necessary to use a BNC Tee-Piece together with a 50 Ω termination cap.

Other Telecine Connections.

All use 75 Ω BNC cables.

Telecine Sync In

House Sync is used to drive the SYNC IN input to the telecine and all other equipment in the suite with the exception of the Pogle Workstation.

Telecine Sync Out

Whether you are running SDTV, HDTV or DATA this output from the C-Reality must be connected to the Pogle Workstation SDTV sync input. Circuitry within the C-Reality automatically provides the correct reference for POGLE.

Telecine Read Frame Pulse

This pulse indicates the start of the 2/3 sequence and will be present at all times as an output from the Telecine.

Telecine Write Vertical Drive Pulse

This is a frame rate (40 ms) pulse that indicates start of a new frame.

Basic Interconnections Pogle to C-Reality & Rascal

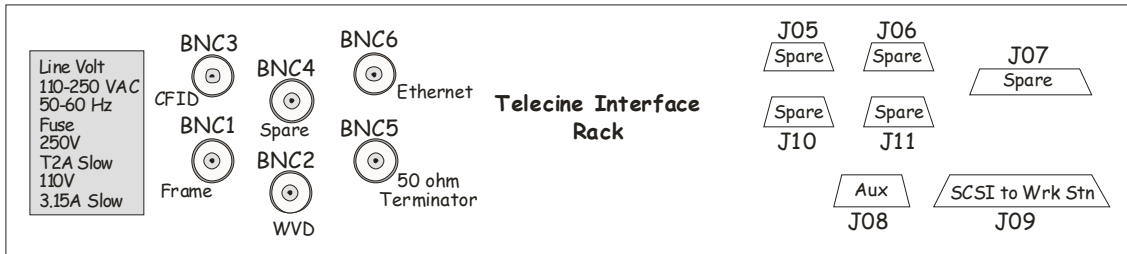
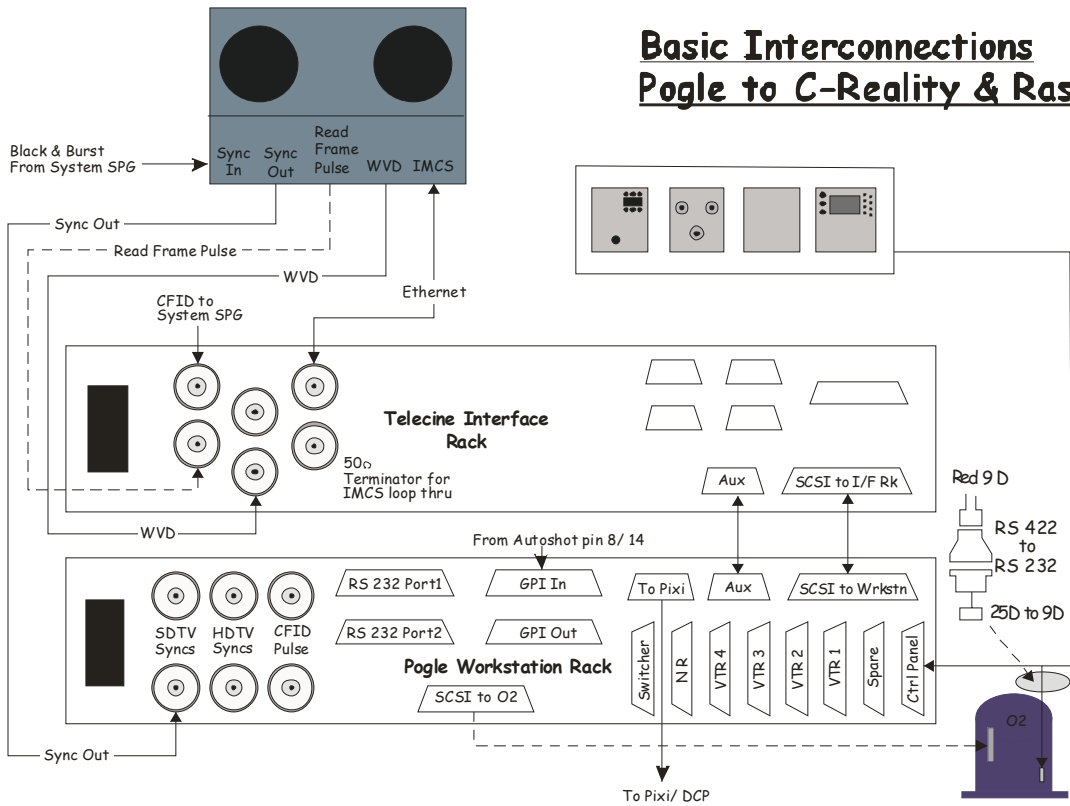

Telecine Interface Rack PBX 6002

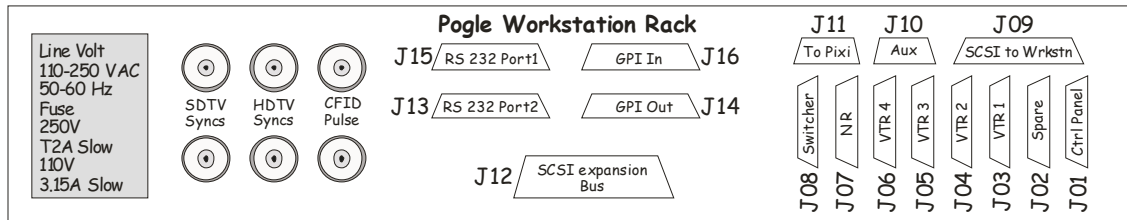

Pogle Workstation Rack PBX 6001

Thompson/ Philips Spirit Interface

Sync In

This should come from the system SPG and be looped to all other equipment in the system, but NOT the Pogle Workstation.

SDTV

Whether you are running standard or high definition, this output from the Spirit must be put into the Pogle Workstation black and burst input.

CFR Out

This pulse indicates the start of the 2/3 sequence and will be present at all times as an output from the Telecine.

SOF Film

This pulse is unusual, as it originates on the Spirit as a 25 way 'D' type connector. You will need an adaptor to take the appropriate pins from the 'D' type onto a BNC connector. This will be provided either by Philips or Pandora (PBX6201). Details of the adaptor can be found in 4.0. There is another pulse that comes out of this connector called SOF Studio, do not use this with the Pogle.

Also note that this pulse is only present whilst the telecine transport is moving.

iMCS

This is the ethernet communication line between the Spirit, Pogle Workstation and the Spirit remote panel provided by Philips. Note that this is a 50Ω BNC cable and must be terminated on the Pogle Telecine Interface rack with a 50Ω terminator.

It is possible that between the Spirit and the Pogle Telecine Interface, you may have the iMCS looped through the Spirit remote panel provided by Philips.

CFID

This pulse comes from the system SPG and is the pulse that indicates the start of the colour field sequence.

Tuning in the pulses on the Pogle Telecine Interface.

Full details of this can be found on page 21, but here are the Spirit specific items.

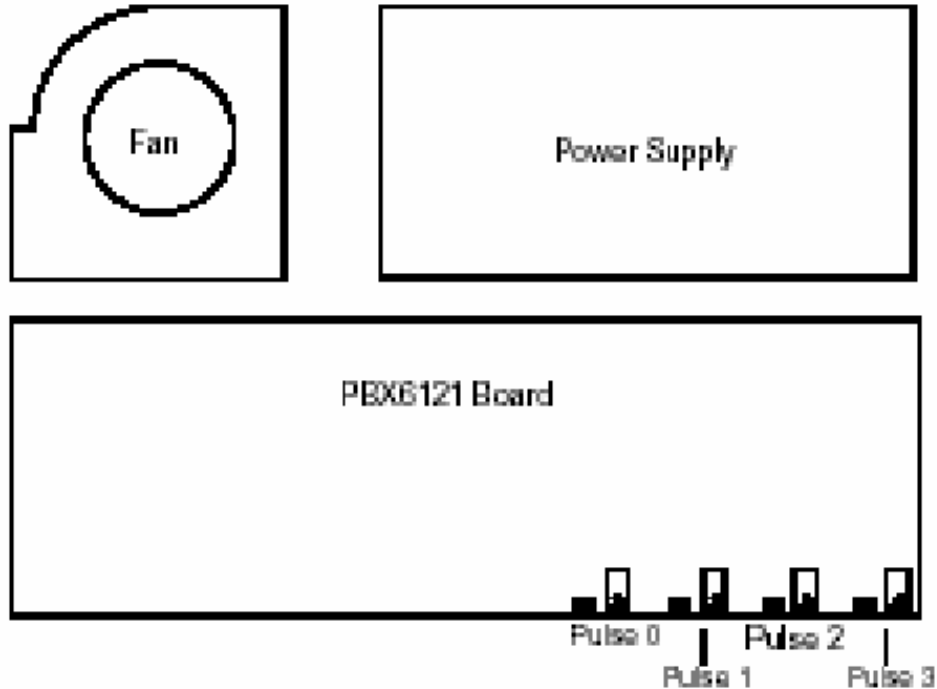

Pulse	Name	Rate	Features
0	CFR	6Hz	Always present
1	SOF	Film 24Hz	Only present when transport is moving
2	CFID	SPG	Start of colour field sequence
3	Not used	--	N/ A

Details of the SOF Film Adaptor.

The PBX6021 supplied by Pandora takes the SOF Film and Studio pulses from the 25 way 'D' type J30 on rack 2 of the Spirit. These are taken out onto BNC connectors.

25 way 'D' Pin Number	Description
10	SOF Film
6	Screen - SOF Film
16	SOF Studio
18	Screen - SOF Studio

Note: Do not use SOF Studio with the Pogle.

Basic Interconnections Pogle to Spirit

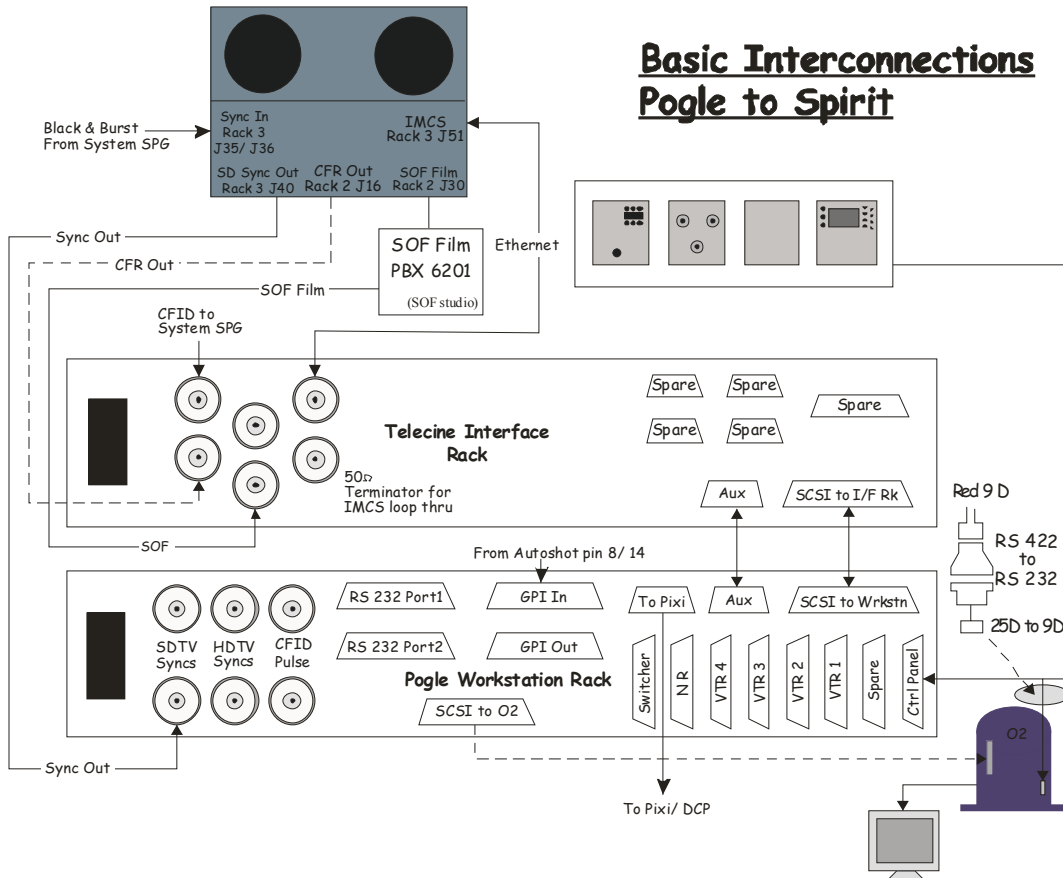

Basic Interconnections Pogle to Shadow

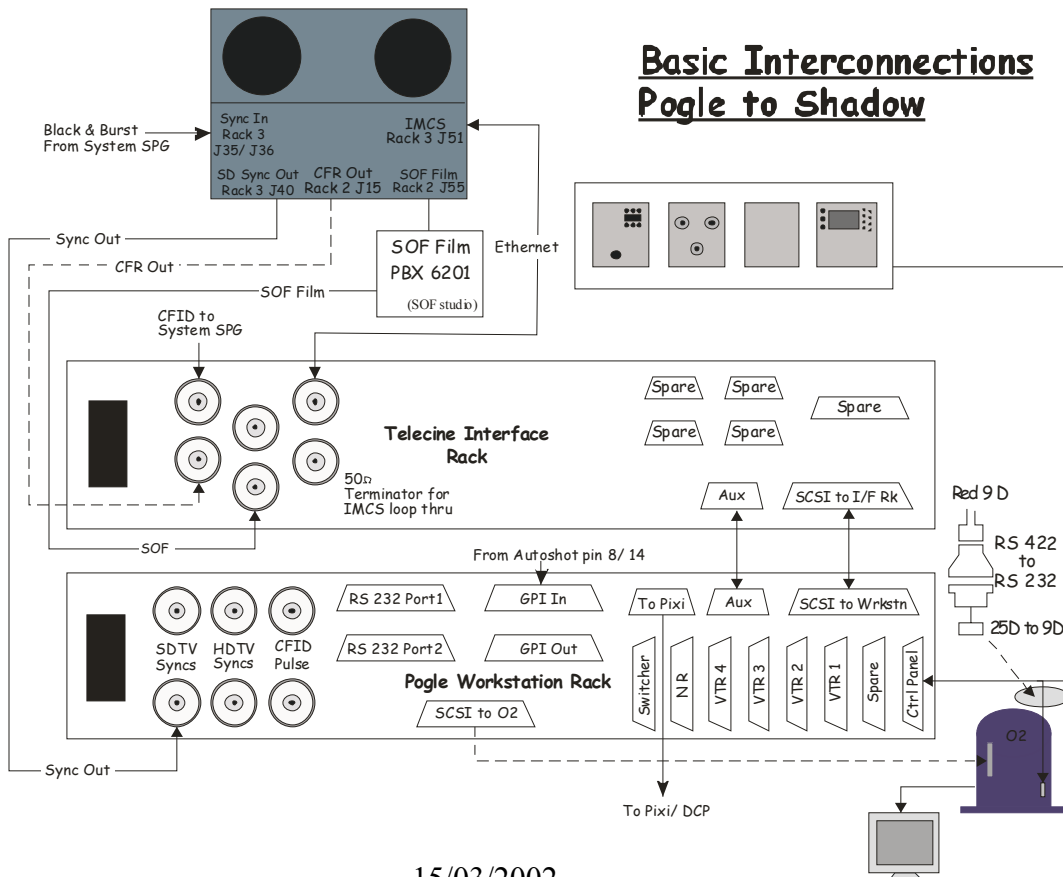

Basic Interconnections Pogle to Specter

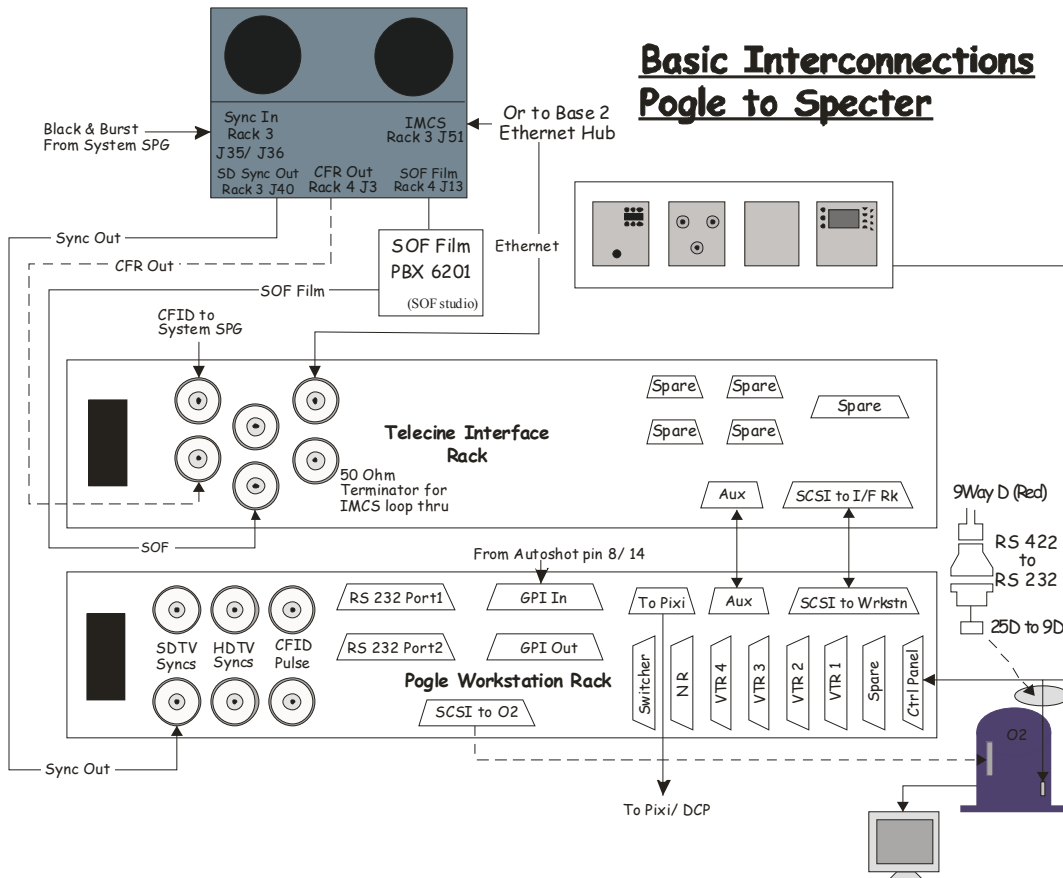

Pogle Rack Rear Panel Connectors for Thompson/ Philips Spirit & Shadow Telecine

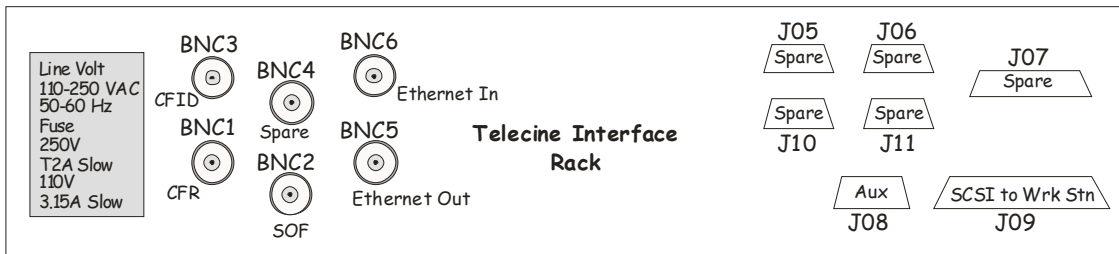

Telecine Interface Rack PBX 6002

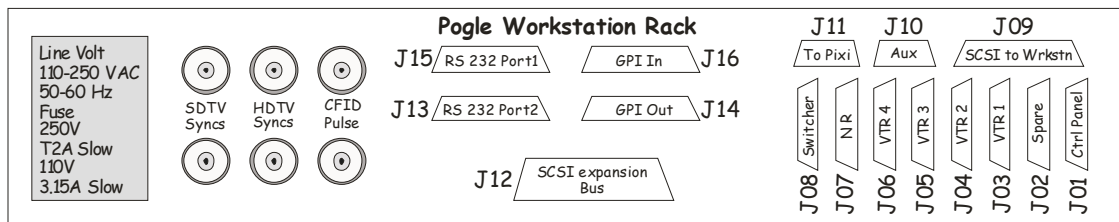

Pogle Workstation Rack PBX 6001

ITK Millennium Interface

Sync In

A connection is tee'd from the main House syncs (75 Ω BNC) to both the ITK Millennium & the Pogle Workstation SDTV Sync In.

Telecine OPD

The Read pulse indicates the 2/3 pull down sequence from the Telecine. It is a 75 Ω BNC connection from the telecine Video Rack OPD to the bottom left hand BNC connection on the Pogle Telecine Interface Rack.

Write Vertical Drive (WVD)

The WVD pulse is a frame rate pulse that indicates the start of frame. It is a 75 Ω BNC connection from the Video Rack on the Millennium to the bottom middle BNC connection on the Pogle Telecine Interface Rack.

Counter Pulses

The Counter pulses are fed from the Telecine's Scan Rack to the Pogle Telecine Interface Rack via a special adaptor box (PBX 6407). This is connected to a 5 pin DIN connector on the rear of the Telecine's Scan Rack, Bi-Phase 2. The output of the adaptor box, a 9 pin D type, is then connected to the rear of the Pogle Telecine Interface Rack, 25 Pin D type.

Control

Control for the Telecine is via a 9 pin RS422 cable connected between the Telecine's Video rack 422 1 & the Pogle Telecine Interface Rack, to the only vertical RS422 connector. This is actually a high speed RS422 Control and requires a special interface card.

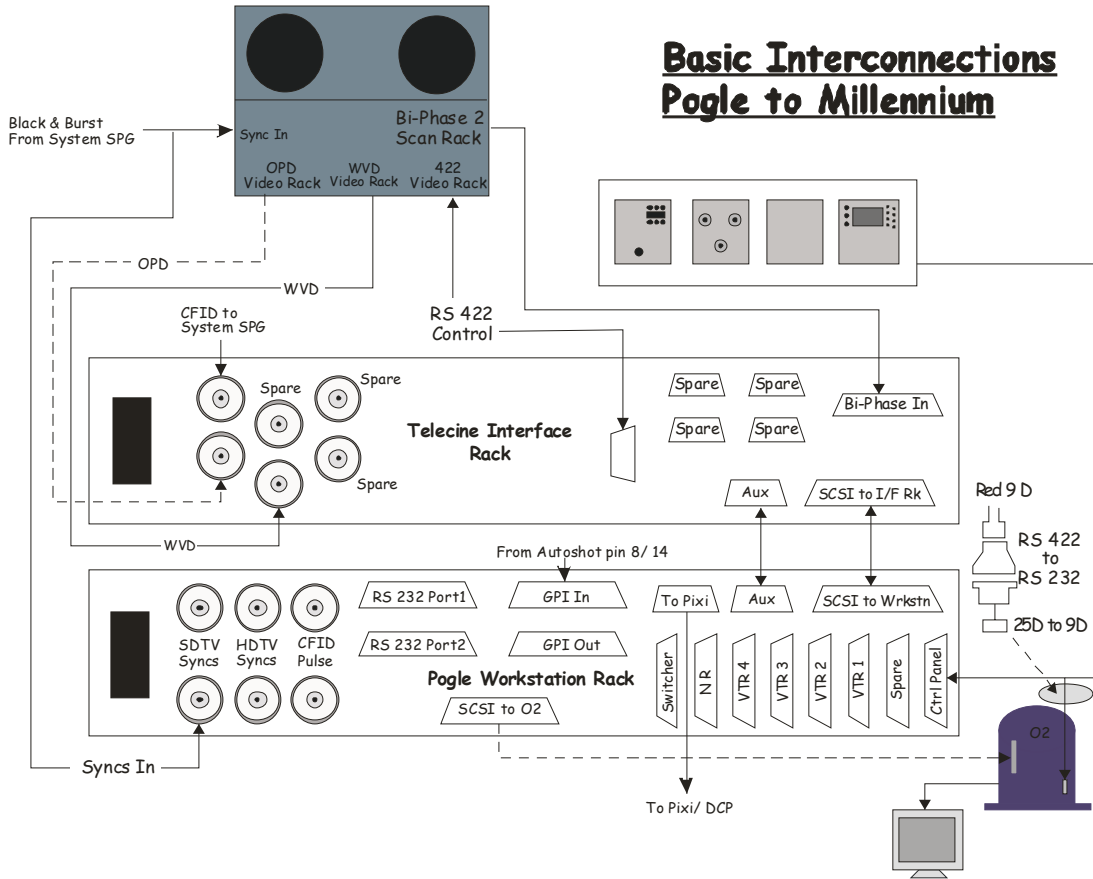

Pogle rear rack connectors for ITK Millennium Interface

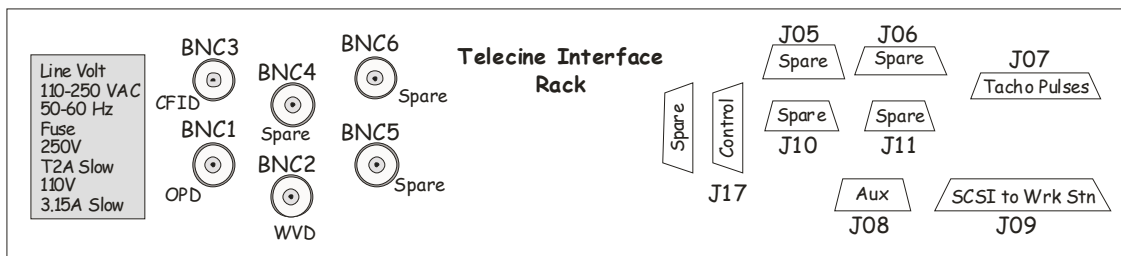

Telecine Interface Rack PBX 6002

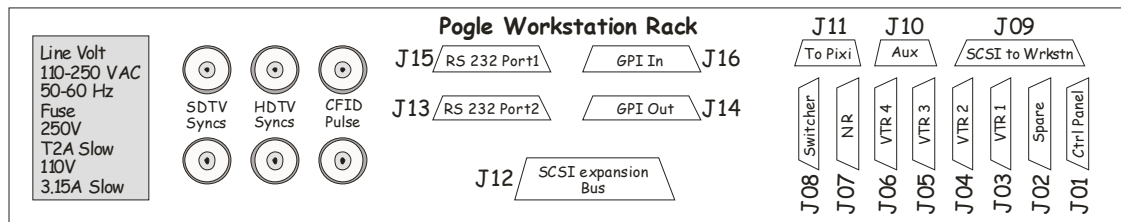

Pogle Workstation Rack PBX 6001

Sony Vialta Interface

Reference Out.

There are two connections for a reference out from the Vialta to the Pogle Workstation, both are via 75 Ω BNC and provide the Input Sync reference to the Pogle to enable it to work in both Standard and High Definition formats.

Sequence

This is a frame rate pulse fed via a 75 Ω BNC. There are two feeds out of the Vialta 1 for a Standard Definition format and the other for a High Definition formats.

Remote 1

The output from Remote 1 on the Vialta is fed into a Pogle converter box (PBX 6009), there are two outputs from this box. The first is a 75 Ω BNC fed to BNC2 on the Pogle Telecine Interface Rack, this is the Write Pulse.

The second is an RS422 Control fed to J17 on the Pogle Telecine Interface Rack; this is the main control interface between the Pogle and Vialta.

Pogle rear rack connectors for Sony Vialta Interface

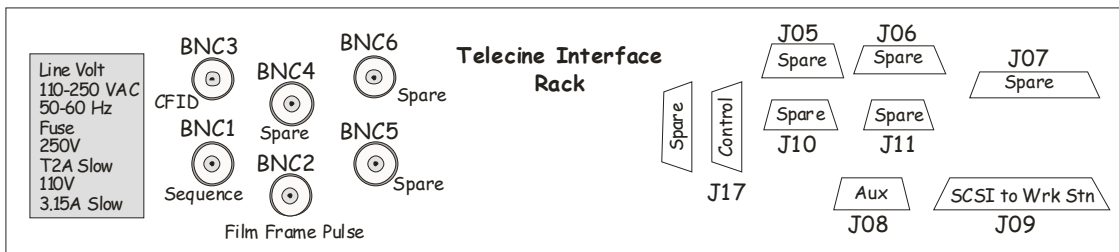

Telecine Interface Rack PBX 6002

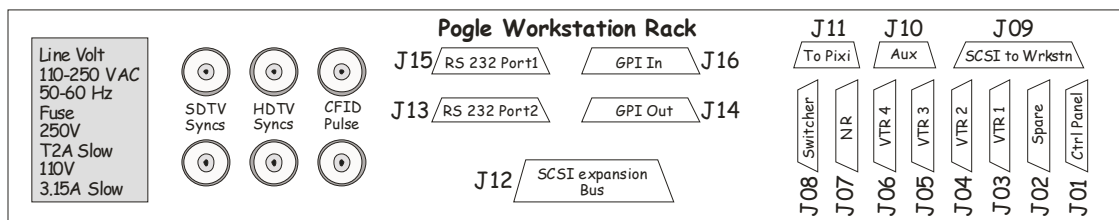

Pogle Workstation Rack PBX 6001

Basic Interconnections Pogle to Vialta

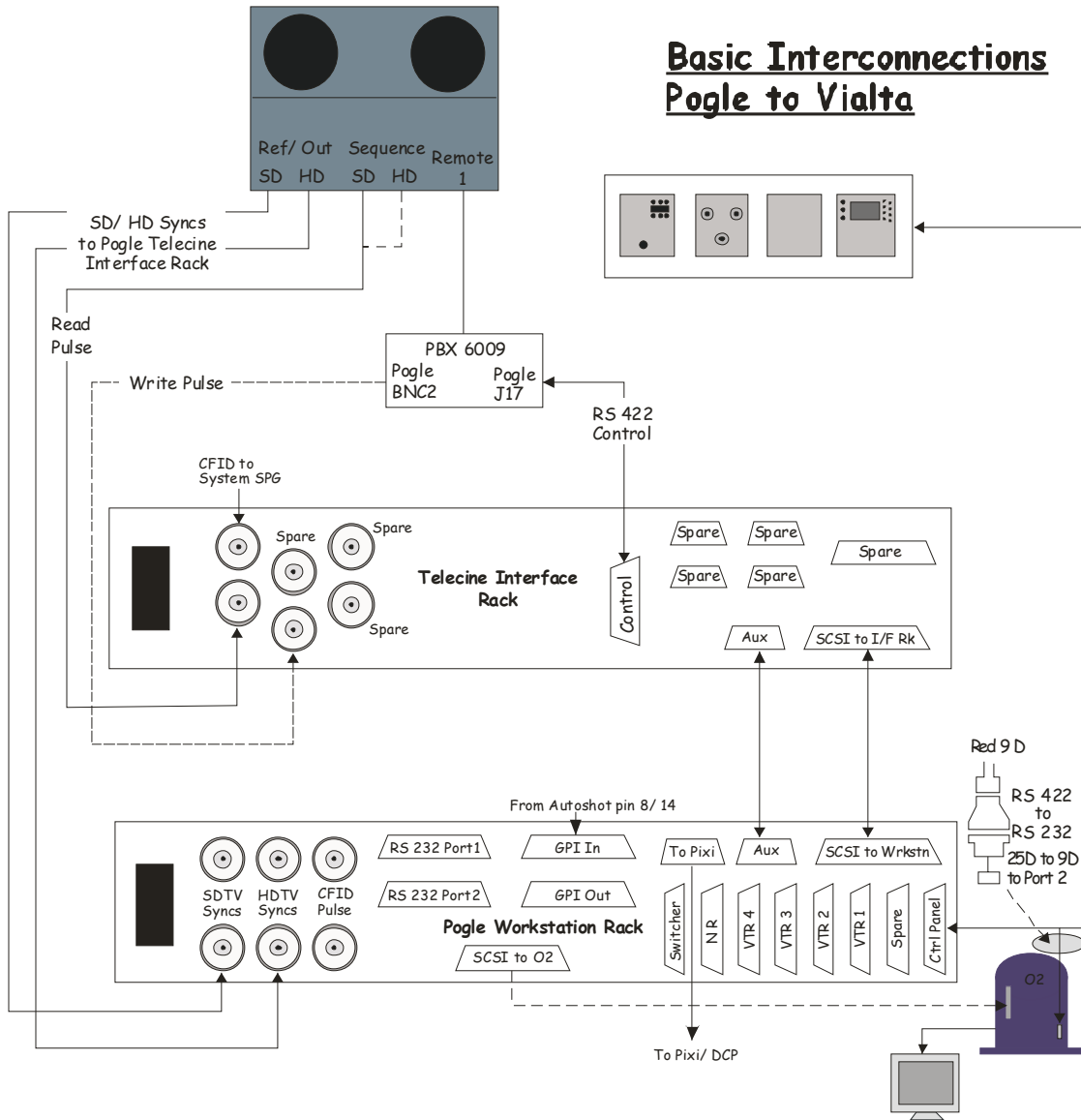

DAV Cineglyph Interface

Ethernet

The Telecine control is a standard ethernet connection, via a hub, to the Pogle Telecine Interface Rack.

Vertical Drive

The Vertical Drive is a frame rate pulse that indicates the start of a new frame. It is connected via a 75 Ω BNC connection to BNC2 on the Pogle Telecine Interface Rack.

Frame

The Frame pulse indicates the pull down sequence. It is connected via a 75 Ω BNC connection to BNC1 on the Pogle Telecine Interface Rack.

CFID

The Colour Field Identifier is fed from the System/ House Syncs and identifies the start of the Colour field sequence.

Pogle Rear Rack Connections for DAV Cineglyph

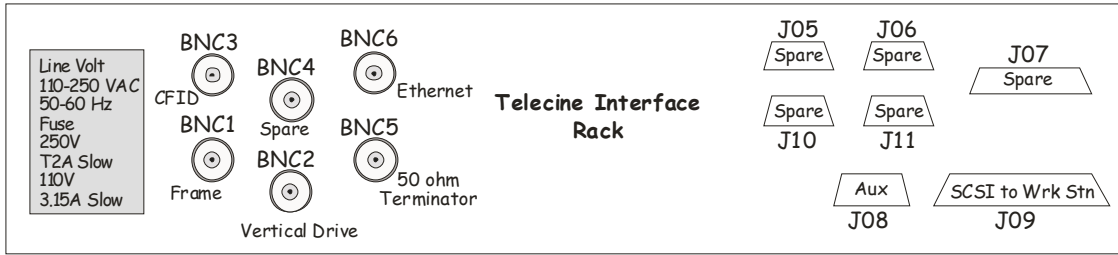

Telecine Interface Rack PBX 6002

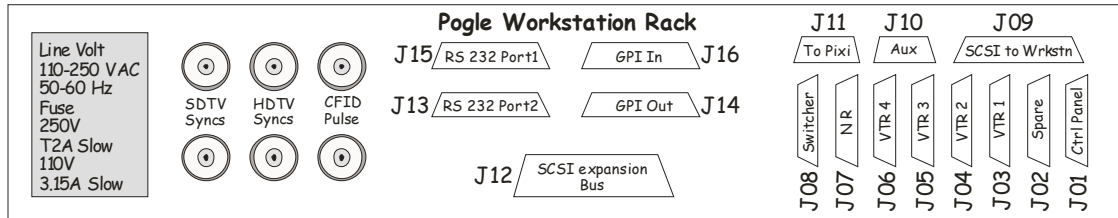

Pogle Workstation Rack PBX 6001