

Pandora International



Pandora PiXi Installation Manual

Pandora PiXi Installation Manual

V1.4 May 2002

System Components

PiXi is a modular colour correction and image processing system from Pandora.

By itself a single PiXi unit can provide colour correction functions for Standard Definition Video SDTV in various formats* *

4:2:2	525 Line
4:4:4	625 Line

360MHz operation is also available for widescreen formats

Optional Cards can be added within the PiXi for High Definition Television Formats* [HDTV]

Interlace Formats

1035 I 47.96Hz	1035 I 50Hz
1035 I 59.94Hz	1035 I 60Hz
1080 I 47.96Hz	1080 I 50Hz
1080 I 59.94Hz	1080 I 60Hz

Progressive Formats

1080 P 23.98Hz	1080P 24 Hz
1080 P 25Hz	1080P 29.97Hz
1080 P 30Hz	

SF Formats

1080 PsF 47.96Hz	1080PsF 48 Hz
1080 PsF 50Hz	

PiXi supports Dual Link HDTV [22:11:11 or 22:22:22] YUV or RGB.
Currently Parallel Interface Only, HD-SDI version in development

The **PiXi** may also be used in combination with a '**PORTAL**' rack to process higher resolution images. The collection of a PORTAL and PiXi's is known collectively as **MegaDEF** and can provide real time [i.e. 30 fps] image processing of image resolutions up to 8000 x 8000 pixels. MegaDEF can also provide non-real time image processing functions from Data Files at any resolution.

A dedicated form of PORTAL [Spirit Interface Chassis] is available for interface directly to the Philips Spirit DataCine and Specter Virtual DataCine.

* * Contact Pandora for current availability and enquiries about other formats.

The PiXi or MegaDEF system is controlled via the '**Pogle Platinum**' telecine control system also from Pandora.

Pogle provides a control surface and a real time operating environment for the colourist, also control of Telecines', VTR's, Noise Reducers and other ancillary equipment commonly found in the colour correction suite.

Note that PiXi is not compatible with earlier Pogle Andix systems however all Pogle's may easily be upgraded to Platinum status.

There are two control links between the PiXi and Pogle...

Standard RS422 [9 pin] is used to control all of the normal colour correction functions.

This link comes from the Pogle Workstation Rack and is updated synchronously once per TV field.

PiXi uses a high speed [250KBaud] protocol so high quality [low capacitance, shielded pair] cable must be used. We recommend that the cable length for this connection is kept as short as possible.

The second link, an **Ethernet connection** is used between PiXi and the SGI computer which provides the GUI for Pogle Platinum. This link is used by the **MegaGamma** and **MegaShape** options to download textures and other graphics information.

Currently the PiXi uses a 50 Ω BNC connection for 10base2 ethernet whereas the SGI computer uses 10/100BaseT on UTP cable. A low cost network HUB or adapter is required to convert between the two formats.

Note that the Co-Axial cable used to provide this connection must be 50 Ω rated [**NOT 75 Ω Video Cable !!!!!**] and must be correctly terminated at each end with a 50 Ω terminator.

Racks and Mounting

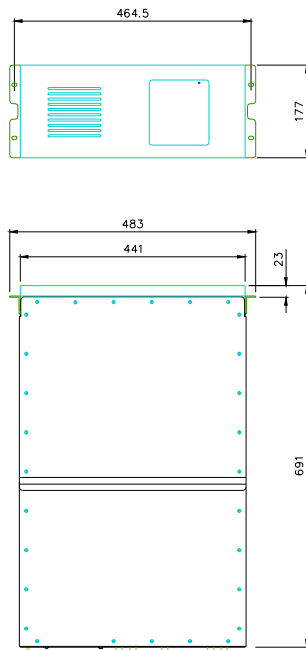

Racks for PiXi and Spirit Interface Chassis are 4U High

Overall Dimensions:

177 cm High. 441 cm Wide.
691 cm Deep.
[Not Including Cables]

Power Requirements:

PiXi -

100–240 VAC 50-60Hz.
Line Current 2A5 max at 240V.
550 VA @110V.
600 VA @240V.

Spirit Interface Chassis -

100-240 VAC 50-60Hz.
Line Current 0A8 max at 240V.
180VA @ 110V.
200VA @ 240V.

Portal -

See separate documentation.

Cooling air is blown horizontally from the right to the left.
[When viewed from the front].

**Great care must be taken to ensure that the PiXi rack has adequate ventilation
overheating will cause unreliable operation and eventually permanent damage.**

Pandora Warranty does not cover damaged caused by overheating.

Pandora supply a rack mounting shelf bracket to support the rack and also to allow the whole rack to be slid forward for service. All fixings for the support shelf are from the front using standard rack screws and cage nuts.

Care should be taken during installation to ensure that the cables connected to each rack have sufficient slack to allow the unit to be pulled forward.

Note that the top cover is split into two sections so that the front half can be removed whilst the unit is still in operation.

WARNING – This equipment **MUST** be earthed.

Ensure that the mains plug or the application inlet remains readily accessible after installation.

General Instructions

General

CAUTION

These servicing instructions are for qualified personnel only. To reduce the risk of electric shock, do not perform any servicing other than that contained in the operating instructions unless you are fully qualified to do so. Refer all servicing to qualified personnel.

Servicing Information

There are no user serviceable parts, refer servicing to qualified personnel. Fuse replacement to be conducted by qualified personnel only.

Cleaning Information

Qualified personnel only shall clean the unit.

Where fitted, Fan Filters and Air Vents shall be checked and cleaned on a regular basis. We recommend at least once per month of continuous operation.

Installation

Caution

The unit shall only be installed by qualified personnel, a two man lift is required.

Unit weight:

PiXi approx. 29kg

Spirit Interface approx. 16kg.

Unit must be installed into a standard 19" rack system to IEC 297, on the bracket provided.

The air-flow through the unit is from right to left. Ensure that there is an adequate ventilation gap on each side of the unit.

Warning

To reduce the risk of fire or shock hazard, do not expose this equipment to rain or moisture.

Caution

To reduce the risk of fire or shock hazard and annoying interference, use the recommended accessories only.

Failure to comply with these instructions may cause permanent damage to equipment or injury to personnel.

Pandora Warranty does not cover situations where equipment has been installed, serviced or modified by non-qualified personnel.

SDTV Installation

A Single PiXi rack may be configured with Serial Input and Output Connections for SDTV applications.

As delivered the following formats are processed.

4:2:2	Y Cr Cb	270MHz
4:4:4	Y Cr Cb	270MHz

Other Options are available by special request.

4:4:4	RGB	270MHz
-------	-----	--------

360MHz [Widescreen] modes are also available.
Please contact the Factory.

2 Inputs can be connected when running in 4:2:2 or 4:4:4 mode.
The active input may be selected from the Pogle GUI.

Currently the PiXi is driven from the Input Video Timing.
Output appears One Video Line later.

A Framestore option is undergoing development.

Shipping

We recommend that you carefully inspect the PiXi Racks when they first arrive. This should be done **BEFORE** power is connected.
Preferably remove the top covers from the units and double check that none of the internal circuit boards or cables has been shaken loose during transit.

Any damage should be reported immediately.

Rack Mounting

The Racks should be mounted using the brackets supplied.
Please read the earlier note about cooling and ventilation.

PiXi is connected to the Pogle Controller via an RS422 link. A 10 meter cable is supplied as standard although other lengths can be specified. Note that the communication runs at a high baud rate so good quality cable and correct construction is essential. Please consult the Factory if you have any requirement to extend this connection.

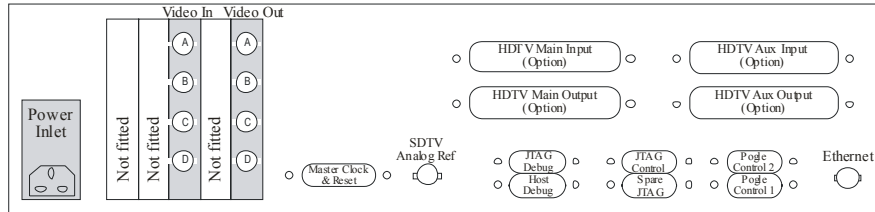

PiXi Rear View [SDTV Option Installed]

Video Connections

Serial Video Connections should be made as follows ...

Video In >>

	4:2:2 Mode	4:4:4 Mode
A	Main 4:2:2 Input	Main 4:2:2 Component
B	Not Used	Main 0:2:2 Component
C	Aux 4:2:2 Input	Aux 4:2:2 Component
D	Not Used	Aux 0:2:2 Component

Video Out >>

	4:2:2 Mode	4:4:4 Mode
A	Main 4:2:2 Output	Main 4:2:2 Component
B	Spare 4:2:2 Output	Main 0:2:2 Component
C	Not Used	Not Used
D	Not Used	Not Used

Note that Inputs and Outputs may be configured separately from the Pogle Controller.
e.g. Input Mode 4:4:4 10 bit + Output Mode 4:2:2 8 bit.

SDTV Analog Ref

This connector is intended for a future Framestore option and is not currently required.

Control Connections to POGLE

A Single RS422 connection is required between the Pogle Workstation [DCP Port] and Control Port 1 on the PiXi.

A 10 Meter cable is provided for this, please see the notes above if a different length is required.

If the MegaShapes software option is fitted the PiXi racks receive shape and texture information directly from the SGI computer used by the Pogle Platinum Controller via the Ethernet connection.

Note that the SGI uses a 10/100BaseT [Twisted Pair] network connection. This must be converted to 10Base2 [Cheapernet] to connect to the PiXi racks. A small network hub box can be supplied by Pandora for this purpose.

Note that 10Base2 uses 50ohm cable and connectors.

DO NOT use standard video parts which are 75ohm.

Correct termination at each end of the cable is critical. Connect the units exactly as shown in the diagram.

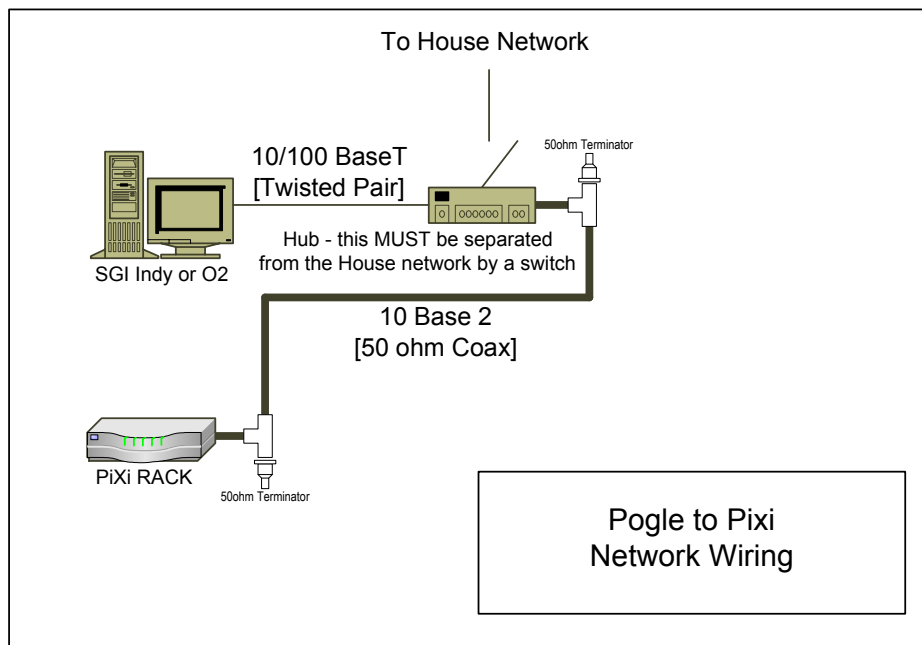

POGLE Platinum setup.

Before switching on the PiXi the Pogle system should first be correctly configured to control it.

- #1] Open the *Pogle Toolbox* by clicking on the small magenta icon on the bottom left of the lower status bar.
- #2] Choose *Room Setup* menu and select the *PiXi/MegaDEF* option as *Secondary Colour Corrector*.
- #3] If another type of Colour Corrector has been previously selected save the new setting by closing the *Room Set-up menu* and then restart the Platinum software and the Pogle Workstation.
- #4] From the *System Defaults* menu in the toolbox select *Recall Factory Defaults* for Secondary Colour Corrector
- #5] Choose the *Save new defaults* for Secondary Colour Corrector to ensure that the normal position for all controls is correctly set-up.
- #6] Open the *DCP Setup* menu from the toolbox and you should now see the PiXi set-up menu.

Select *625 Mode* [bottom Line]

Select *Downstream Video* mode in the top left hand corner.

Select *Lock to Input Video*

Select *Input Options* as appropriate >>>

4:2:2 // 4:4:4
8 bit // 10 bit
Input A // Input C

Select *Output Options* as appropriate >>>

4:2:2; // 4:4:4
8 bit // 10 bit

Close the *DCP Setup* window to memorise the above settings.

NOTE:

Now repeat the above procedure with *525 line mode* selected.
The Options in the *Setup* window are memorised individually for each line standard.

- #7] From the *Vault* you will need to find the control panels for Pixi.
Try searching for *MEGA*.

Mega1 is the panel for the simple **Six Vector Colour Corrector**.
Mega2 controls the **advanced Colour Corrector** and **window functions**.

You will have either three or six channels of Mega2 depending on the options you purchased.

MegaShapes provides tiling and RGB control for the **Shapes** option.

Once you have found the appropriate panels remove any old [DCP] panels from the display and save a new **VIEW**.

Note that some of the controls on the PiXi correspond to similar controls on the old DCP but **DO NOT** try to use the old panels as newer [PiXi only] functions will be missing or set to the wrong state.

Switching on PiXi

After the Pogle has been configured correctly you may switch on the PiXi rack

Note that all software for the PiXi is uploaded from Pogle during bootup. A PiXi on it's own or connected to a Pogle that is not configured correctly **will NOT pass video !!!**

Open the Platinum Debug window the first time that you switch on the PiXi and observe what happens.

The correct sequence is something like this

- #1] When the PiXi first wakes up it requests a software upload from Pogle. This should take less than a minute. If there are any problems with the software upload [checksum failure etc etc] it will start again.
- #2] When the PiXi has received the correct software it will reset its internal buses and begin to configure the internal modules. During this time you should see a list of the internal resources for the system.

Currently there are four types of internal module

- Primary Colour Corrector
- Mega One [Six VectorCC]
- PixCELL
- CoBRA

PixCELL is the card that actually performs the Secondary Colour Corrections within isolated regions
CoBRA generates an isolation key signal based on colour information and shapes.

Primary /PixCELL and CoBRA cards have three processors which are listed A B C as they start up.

On the Primary Colour Corrector card

A = Red Channel

B = Green Channel

C = Blue Channel

On both the PixCELL and CoBRA the three processors correspond to the three channels of colour correction provided by each card.

Mega 1 [Six Vector Colour Corrector] does not use DSP processors as the entire function of this module is built inside a programmable logic device.

#3] Once all of the internal processors are configured the PiXi searches for video data on its input and should hopefully find a vertical sync signal. You should see a display showing the approximate operating frequency of each of the DSP's. This corresponds to Vertical Sync and so will be 25 or 30Hz depending on your TV system.

Spirit 2K Installation

For this configuration 2 PiXi Racks are required plus a Spirit Interface Chassis.

Total continuous bandwidth for the Spirit system is about 430 MBytes per sec. Regardless of the output mode of the Spirit DataCine, MegaDEF always processes a full resolution image equivalent to about 2048 x 1536 Pixels x 30Bits.

Data is provided from the Spirit as 10bit [Lin or Log] via three cables, one per channel Red, Green and Blue. Each carries 20 Bits of Data at approx. 60MHz. A separate cable carries Clock and Timing Information.

Within the Spirit Interface Rack data is broken down into four colour processing channels each 30bits [RGB] at 30MHz. [When data is provided as 10bit LOG the PiXi converts this to a 14bit linear format for internal processing.]

Each PiXi rack then processes two channels.

Line memory within the Portal rack buffer the data and multiplex so that PiXi rack A receives Lines 1 and 2 whilst rack B receives lines 3 and 4 and so on.

Rack A is Master and must be operational otherwise the Spirit Interface will not provide any Sync information. It is possible to disconnect [or switch off] PiXi B for test purposes in which case only every other line pair of the image will be visible. Each PiXi rack is identical and runs the same software so it is possible to swap them over.

Currently the interface between the PiXi racks and Spirit Interface is parallel RGB using 100 pin AMP connectors [Similar to HiPPi].

Note: Although Hippi style connectors and cables are used for this interface, the data carried is not in Hippi format and must not be connected to other Hippi equipment or routers!!

Pandora provide 1 Meter length for the 100 pin cables meaning that the three racks must be mounted in adjoining positions within the rack.

The cables between MegaDEF and the Spirit are 5 Meters in Length. This is critical as an internal delay must be set within the Spirit to compensate for the clock skew along the cable.

For this reason these cables **must NOT be shortened** and **CANNOT be supplied in a longer length.**

Shipping

We recommend that you carefully inspect the PiXi and Spirit Interface Racks when they first arrive. This should be done **BEFORE** power is connected. Preferably remove the top covers from the units and double check that none of the internal circuit boards or cables has been shaken loose during transit.

Any damage should be reported IMMEDIATELY.

Rack Mounting

The Two PiXi Racks and the Spirit Interface Chassis should be mounted in adjacent rack positions using the brackets supplied.

It is suggested that the Spirit Interface Rack is mounted at the bottom as this carries most of the bulky cables to the Datacine. Altogether 12U of rack space will be required.

It may be necessary to make some adjustments inside the Portal rack during installation so care must be taken to ensure that the cables at the rear are suitably dressed to allow the unit to be slid forward whilst still in operation.

Please read the earlier note about cooling and ventilation.

Problems **WILL** occur with both the MegaDEF and the Spirit Datacine if the air conditioning system is unsuitable!!!

Connection to Spirit DATACINE [Or Specter Virtual DATACINE]

Before Installing the MegaDEF normal operation of the Spirit together with the Pogle control system should be confirmed. The Spirit requires software revision 3.33 [or later] for correct operation – if an earlier version is fitted **DO NOT** install MegaDEF without first contacting Philips Service.

- #1] Three 50 way cables carry RGB Data from Spirit Rack Two to the Input of the Spirit Interface Rack.
[Virtual Datacine Rack Four – HiPPi Interface]
- #2] A similar set of three cables carry the data back to the Spirit Rack Three [Spatial Interpolator]. *[Virtual Datacine uses identical Rack Three]*
- #3] An additional 25 way cable carries clock and Timing Information from Spirit Rack 2 *[or VDC rack 4]*.

POWER DOWN the Spirit before proceeding!!

It will first be necessary to remove the Internal 50 way linking cables that connect Spirit Rack 2 to Rack 3. The cables are threaded into the internal framework wiring of the machine and should not be completely removed however it may be necessary to secure the ends with cable ties to ensure that they do not move about inside the machine and cause damage. [The cast Aluminium connector covers are quite heavy!].

Note that the Clock connection marked **PULSES OUT J51** on the rear of **Rack Two** should **not** normally **be in use**. Do not confuse this connector with a similar one intended for the electronic steadiness option.

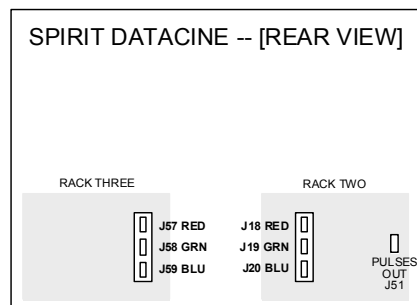
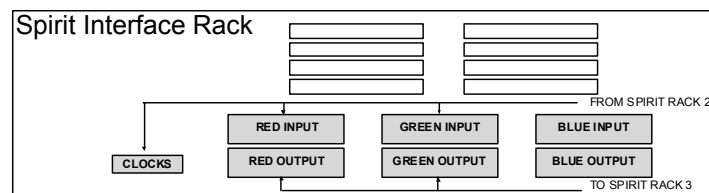

A TOTAL OF SEVEN CABLES SHOULD BE INSTALLED !!!

Connection details for PHILIPS SPIRIT, SPECTER and SHADOW

Spirit

RGB Rack 2 [to MegaDEF]	R = J18	G = J19	B = J20
RGB Rack 3 [From MegaDEF]	R = J57	G = J58	B = J59
Pulses Out	Rack 2: J51		

Specter [Virtual DataCINE]

RGB Rack 4 [to MegaDEF]	R = J18	G = J19	B = J20
RGB Rack 3 [From MegaDEF]	R = J57	G = J58	B = J59
Pulses Out	Rack 4: J9		

Shadow

RGB Rack 2 [to MegaDEF]	R = J41	G = J40	B = J37
RGB Rack 3 [from MegaDEF]	R = J57	G = J58	B = J59
Pulses Out	Rack 2: J66		

In **All** cases **MegaDEF output connects** to the same **Rack 3 [Spatial Interpolator]**
The **other Rack** which drives **MegaDEF input** is **specific to the machine type**.

Bypass Wiring

In order to check the correct operation of the Spirit Interface it is a good idea to cross connect the output of the Interface Chassis to the input thereby isolating the PiXi Colour Corrector units.

A total of Four 100 pin [Hippi] cables should be connected as shown ...

Spirit Interface Rack

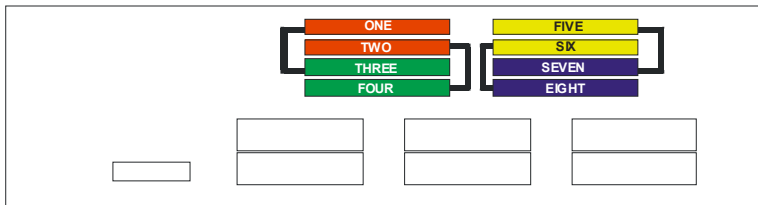

Bypass Wiring

Cable #1	Link Two to Four ***	carries Video Line One
Cable #2	Link One to Three	carries Video Line Three
Cable #3	Link Six to Eight ***	carries Video Line Two
Cable #4	Link Five to Seven	carries Video Line Four

If all is well the Spirit may now be switched back on and a picture will be displayed as normal.

*** NOTE

The two cables marked [2 →4 and 6→8] carry Master Sync Data and both **MUST** be present before any output will be seen from the Spirit.

It is possible to remove the other two cables in which case the output will show only every second pair of lines. You may need to operate the Spirit Zoom control before you can see the effect of this.

Some Debug Tips

So what happens if you connect the Spirit Interface Chassis up in bypass and you still don't get a picture through the Spirit?????

Fortunately there are some status LED's inside the rack which may help.

If you open up the **Rear top cover** [closest to all the cables] you will see two boards. The **lower board** [PBX210AKA] is the **Input board** which receives signals from the Spirit and converts them to PiXi format.

The **Upper board** [PBX210BKA] does **exactly the opposite**, receiving signals from the PiXi's and converting them back to the Spirit world.

On the **lower board** you should just about be able to see some LED's on the left [viewed from the rear] these are shown in the following diagram

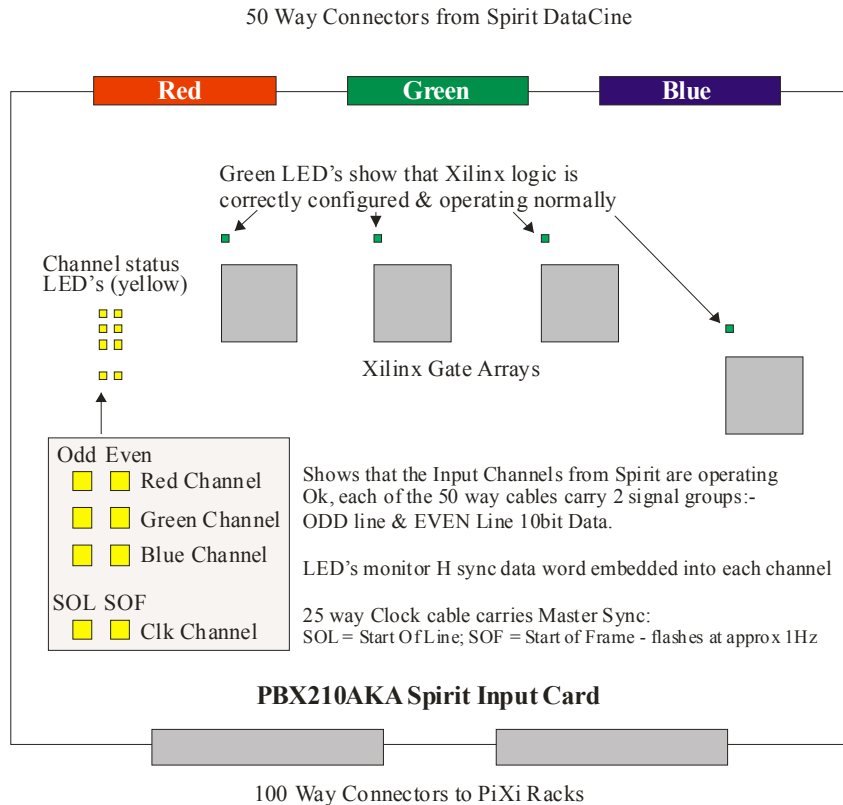

The Four Green LED's should be illuminated constantly showing that the logic is operating correctly. If these are not on suspect either the Logic configuration Prom or the power Supply.

The Yellow LED's show status of each of the four input cables from the Spirit. [RGB data and Master Clocks].

All yellow LED's should be constantly illuminated with the exception of the SOF lamp which flashes slowly.

You should see that each pair of LED's will extinguish when the corresponding cable is removed. If a pair of LED's are not on try swapping the RGB input cables around to see if the fault follows.... If not you might try swapping the internal ribbon cables.

Be aware that if the cables are not correctly screwed in at the rear of the Spirit then the weight of the die-cast cable shell may be enough to cause the cable to fall out -- especially when you're not looking!

Please note also that if there is a fault either on the Clock cable or the RED video channel then the Spirit Interface rack will produce no output back to the Spirit and you will probably only be able to transfer completely black film. [RED video channel is used internally as master to synchronise Green and Blue].

It is possible for diagnostic purposes to run without either Green or Blue channels and it is also possible to swap any channel with any other providing you always have a cable driving the RED input.

If all is well on the Input card check the Output card LED's detailed below. Hope that if you have a fault that it is on the Output card as it's the one on top and it's easier to fix.

Note a couple of common problems that have cropped up and are subject to design review.....

#1] The 25 way Master Clock cable attaches to a 25way Dee connector which sits on a piggy back connector above the input card. If the Portal rack has been treated roughly by the Shipping Company then it is possible for the connector joining the two boards to pop out. This is easily rectified and is unlikely to occur again in normal use. The same thing could possibly happen to the 100 way Hippi connectors which are also mounted on daughter cards although these are a lot more resilient.

#2] Make sure that the fans within the Spirit Interface rack [and also the PiXi racks] are operating. The fans use a dedicated 12V rail which can fail in isolation to the main 5V and -5V rails.

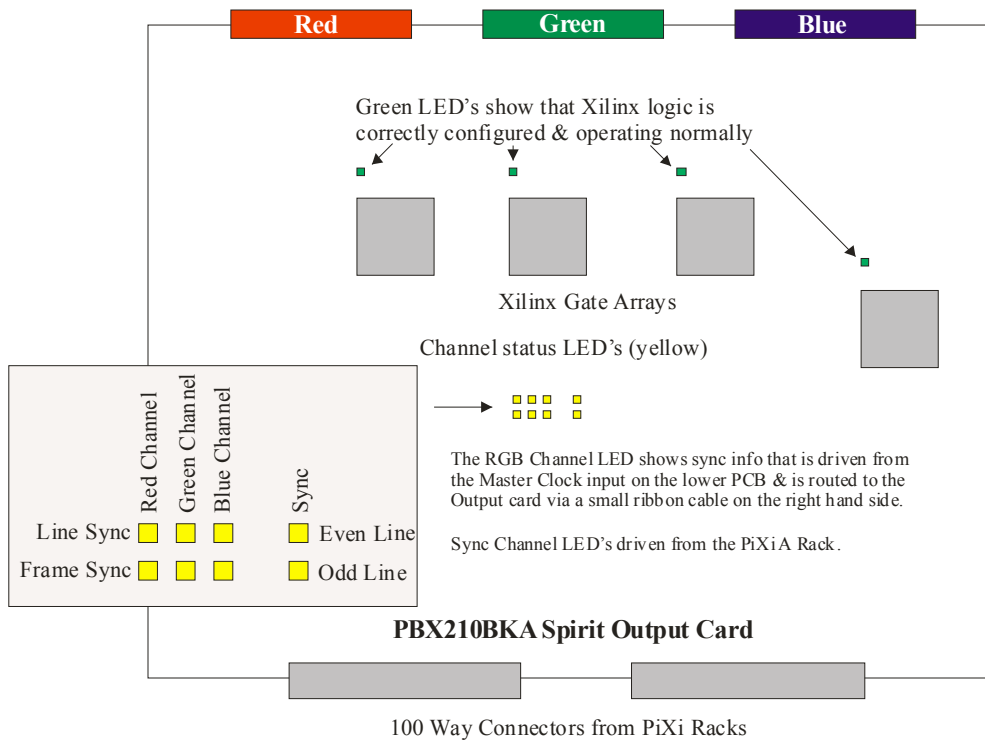

Note that the Six LED's representing Output Syncs should normally be operational if all is well on the input card. The Line Sync [SOL] LED is on continuously while the Frame Sync [SOF] flashes at approx 1Hz.

If these LED's are not operating then there is a problem either with the input clock cable or the short ribbon cable that carries signals between the two PCB's.

Master Sync LED's [the right hand pair] are driven from the two lower 100pin connectors on this card [normally driven from the output of PiXi Rack A]. These LED's should also flash at approx. 1Hz.

Note that it is not a problem if the LED's do not flash in unison but they should operate at the same rate.

If all is well you can now move on and connect up the two PiXi racks!!!!

Connection between the Racks

#1 Data Cables

These should be colour coded for easy identification.

Four Cables connect between each PiXi rack and the Portal [total 8].

Video Data Inputs to PiXi

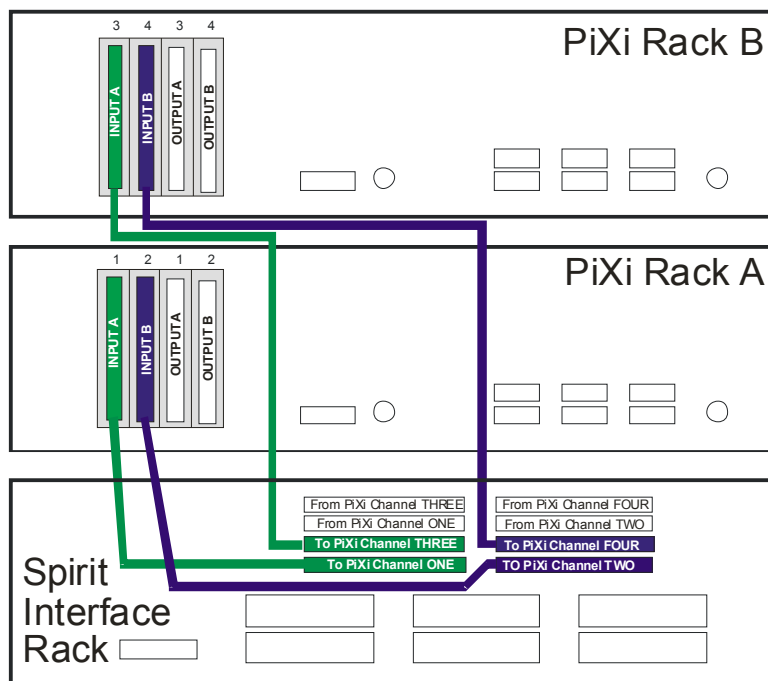

PiXi - Spirit Interface Wiring
Part One

Video Data Outputs from PiXi

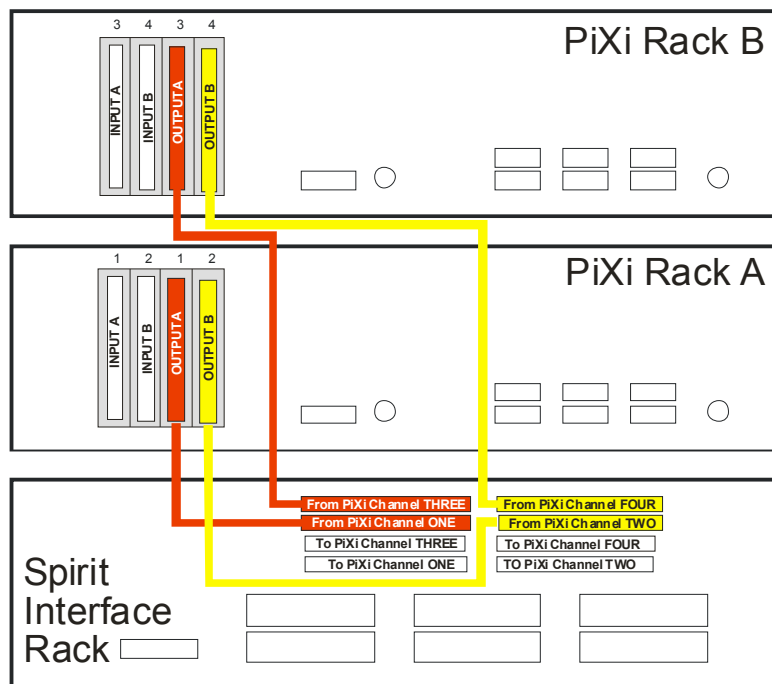

PiXi - Spirit Interface Wiring
Part Two

#2 Master Reset & Control Cables

Master Clock & Reset

A cable is supplied to interconnect the Master Clock connections on the rear of each PiXi rack [15 way DEE].

This cable carries a common reset signal to both racks.

It does not matter which way around this cable is connected.

RS422 Control

The PiXi racks are connected to the Pogle Workstation DCP Control Port using a special cable adapter. This may be extended to any reasonable length using a standard 9 pin RS422 cable.

Note that the three cables connecting the adapter box and the PiXi's MUST be connected in the correct order.

RACK A has two cables connected to ports 1 and 2.

RACK B has just a single cable.

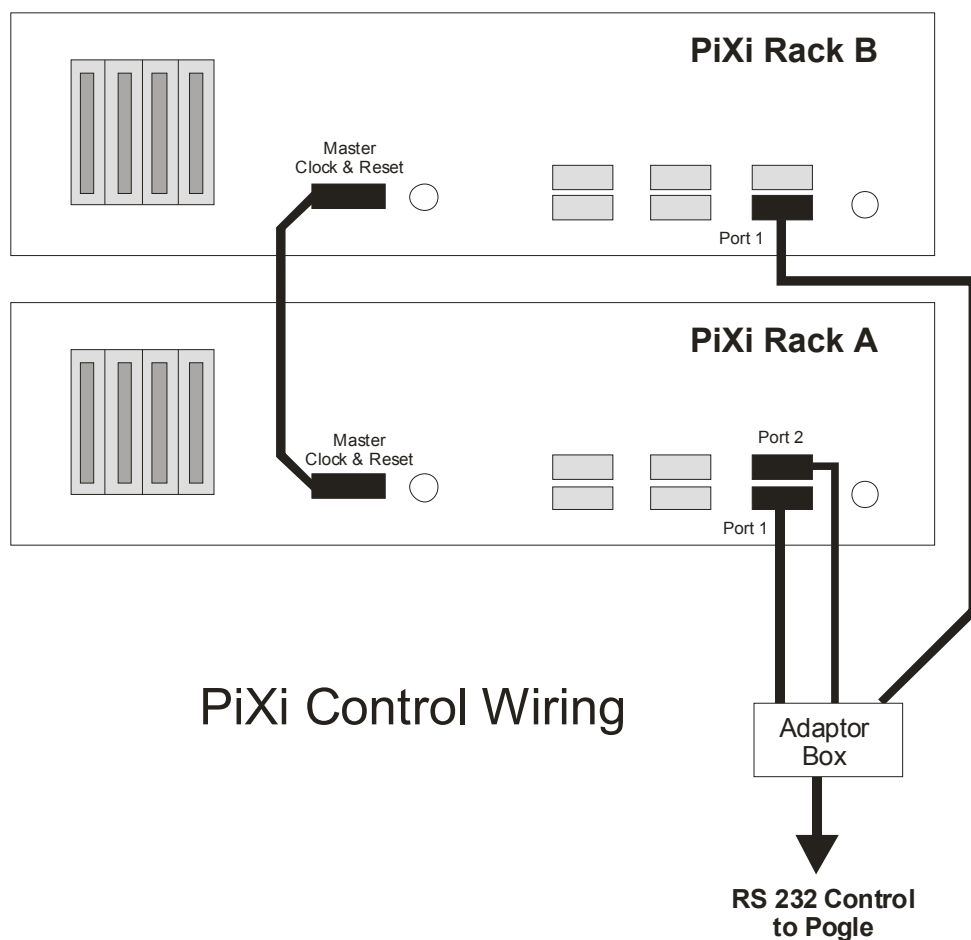

#3] PiXi ↔ POGLE NETWORK WIRING

If the MegaShapes software option is fitted the PiXi racks receive shape and texture information directly from the SGI computer used by the Pogle Platinum Controller. Note that the SGI uses a 10/100BaseT [Twisted Pair] network connection. This must be converted to 10Base2 [Cheapernet] to connect to the PiXi racks. A small network hub box can be supplied by Pandora for this purpose. Note that 10Base2 uses 50ohm cable and connectors. DO NOT USE STANDARD VIDEO PARTS which are 75ohm.

Correct termination at each end of the cable is critical. Connect the units exactly as shown in the diagram.

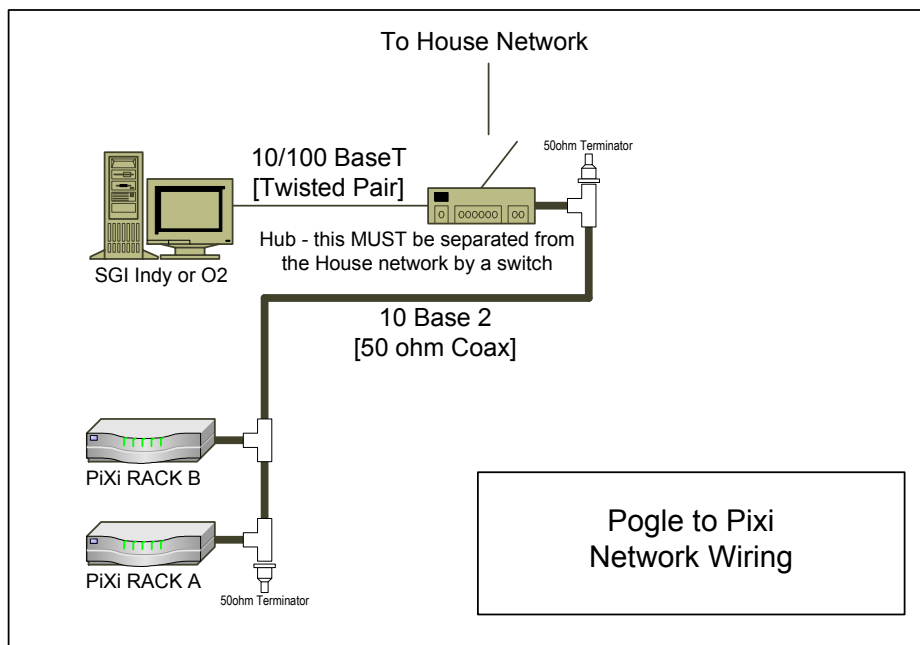

Note:

If the PiXi/MegaDEF is mounted more than 10-20 meters from the SGI computer it would be better to mount the hub local to the colour corrector and to make the connection between using Cat5 Twisted Pair Cable.

POGLE Platinum Setup

Before switching on the MegaDEF the Pogle system should first be correctly configured to control it.

- #1] Open the *Pogle Toolbox* by clicking on the small magenta icon on the bottom left of the lower status bar.
- #2] Choose *Room Setup* menu and select the *PiXi/MegaDEF option as Secondary Colour Corrector*.
- #3] If another type of Colour Corrector has been previously selected save the new setting by closing the *Room Set-up menu* and then restart the Platinum software and the Pogle workstation.
- #4] From the *System Defaults* menu in the toolbox select *Recall Factory Defaults* for Secondary Colour Corrector
- #5] Choose the *Save new defaults* for Secondary Colour Corrector to ensure that the normal position for all controls is correctly set-up.
- #6] Open the *DCP Setup* menu from the toolbox and you should now see the PiXi set-up menu.

When used within the Spirit the operational mode of the colour corrector should **ALWAYS** be set to *Upstream* regardless of the video standard selected on the Spirit.

In this mode all of the user and system blanking controls and also 4:2:2 4:4:4 setup are disabled.

For convenience Spirit output mode controls [525/625/1080/1125 etc] have also been moved into this menu but can still be controlled from the Spirit DATA menu.

Open the Platinum Debug window the first time that you switch on the MegaDEF and observe what happens.

The correct sequence is something like this

- #1] When the PiXi first wakes up it requests a software upload from Pogle. This should take less than a minute.
If there are any problems with the software upload [checksum failure etc etc] it will start again.
- #2] When the PiXi has received the correct software it will reset its internal buses and begin to configure the internal modules
During this time you should see a list of the internal resources for first the A rack and then the B rack

Currently there are four types of internal module

Primary Colour Corrector
Mega One [Six VectorCC]
PixCELL
CoBRA

PixCELL is the card that actually performs the secondary colour corrections within isolated regions

CoBRA generates an isolation key signal based on colour information and shapes.

Primary /PixCELL and CoBRA cards have three processors which are listed A B C as they start up.

On the Primary Colour Corrector card

A = Red Channel
B = Green Channel
C = Blue Channel

On both the PixCELL and CoBRA the three processors correspond to the three channels of colour correction provided by each card.

Note that for 2K operation PixCELL and CoBRA cards are used in pairs to provide the data rate.

Therefore if two cards are fitted into each rack the system provides 3 channels of advanced secondary colour correction.

6 Channels requires four cards per rack.

Mega 1 [Six Vector Colour Corrector] does not use DSP processors as the entire function of this module is built inside a programmable logic device.

#3] Once all of the internal processors are configured the PiXi searches for video data on its input and should hopefully find a vertical sync signal.

Switching MegaDEF On and Off

Spirit DataCine should be powered on before switching on the MegaDEF

Although it is possible to get everything running in any order we recommend that either all three racks are powered up together or if this is not possible then in the following order

- #1 Spirit Interface Rack
- #2 Slave PiXi [Rack B]
- #3 Master PiXi [Rack A]

There is no software running in the Spirit Interface rack and so it should never need to be reset or power cycled.

When the Master PiXi rack is powered on [or Reset] it will send a request to the Pogle controller for a software update. All the software for PiXi is stored on the Pogle Platinum hard disk to make system software updates easier.

When the software is transmitted by the POGLE both the A rack and the B rack receive a copy --- it is for this reason that it is better to power on the master PiXi rack last.

If the PiXi racks have been powered on in the wrong order it is possible to use the reset button at the rear which should reset both racks simultaneously.

Note however that if you push reset during the middle of a software upload then the Pogle will carry on sending and everybody will get confused.

In theory the PiXi will realise that they have only part of the software uploaded [there are various checks made at the end of transmission] and will ask again.

If you are having problems please wait for the upload to finish [watch the Platinum debug window] and then reset both PiXi's again.

The MegaDEF system is only driven as a slave from the Pogle controller consequently it may be powered down at any time and in any sequence without loosing any information from the users colour correction file.

This of course DOES NOT apply to either the Pogle workstation or the SGI computer driving the GUI. The POGLE system itself should be powered down in the recommended way by first choosing the QUIT PLATINUM option from the toolbox and then executing a shutdown sequence on the SGI.

Note that because all of the software for PiXi//Megadef is uploaded from the Pogle Platinum control system the unit WILL NOT FUNCTION unless it is connected to a suitably equipped Pogle Workstation running the required software version.

Some more Debug tricks

The PiXi / MegaDEF system is very modular, built from a common set of components it is possible to swap things around in order to locate problems.

For example all of the PixCELL and CoBRA cards within the Pixi racks are identical. The function that they provide is determined by the card position into which they are placed and so it is possible to swap any two cards around without upsetting the system.

Similarly the Two PiXi racks are each identical, the designation of A [Master] and B [Slave] is determined by the order in which the video and control cables are connected.

The hardest problem with the 2K Spirit system is to determine in which rack or which channel the problem occurs.

Supposing, for example, you have a fault that appears as bit stuck in the red video channel. The first question to ask is “is this problem in all or some of the PiXi channels.”

In order to determine this use the Spirit Zoom function, as this is achieved electronically downstream from the PiXi the Zoom effectively amplifies the output signal from the MegaDEF. Look closely at individual lines.

If the problem can be observed to affect ALL lines then it is very likely that this is either within the Spirit itself or within the Spirit Interface rack.

Bypass the PiXi's as detailed above and check to see if the fault is still visible.

Try swapping the 50 way cables to and from the Spirit i.e. RED and GREEN channels to see if the fault lies within a particular channel or within the wiring.

If all else fails try isolating the Spirit Interface and re-connecting the internal wiring of the Spirit.

If however the problem appears only to affect every other line or pair of lines then it is likely to be within one of the PiXi racks.

One easy way to find out which one is as follows

Use the Master Gain Control on the PiXi Primary corrector to bring the signal down to black.

Now disconnect the RS422 control cable from one or other of the PiXi racks.

Reset the primary colour corrector to a normal setting and now you should only see every other line pair of the image [as the disconnected PiXi remains black]. Can you still see the problem????

If not then try repeating the process and this time disconnecting the other PiXi.

Once you have traced the problem to a particular rack then you need to work out which channel within that rack, this is slightly more difficult however one thing that helps is that it is possible to swap over the two channels connected to each PiXi. In fact this will only affect the way that shapes are drawn and so can be very useful for debug.

Another helper is to try to use the colour corrector to isolate the problem. If for example you have red lines appearing through the image can you isolate and change these with the secondary colour corrector. If the answer is yes then the problem is

likely to occur near the input. If not then the problem must be on the output after the secondary colour circuitry.

Does the fault appear when viewing the PiXi internal test pattern [generated near the input]???

If all else fails don't panic, contact Pandora via Email at service@pandora-int.com or by fax or phone.

PiXi HDTV Adapter Boxes

To convert between various HDTV Parallel Wiring Standards Pandora now supply an adapter box.

This must be attached to the rear of the PiXi panel using metal clamps as shown in the diagram below.....

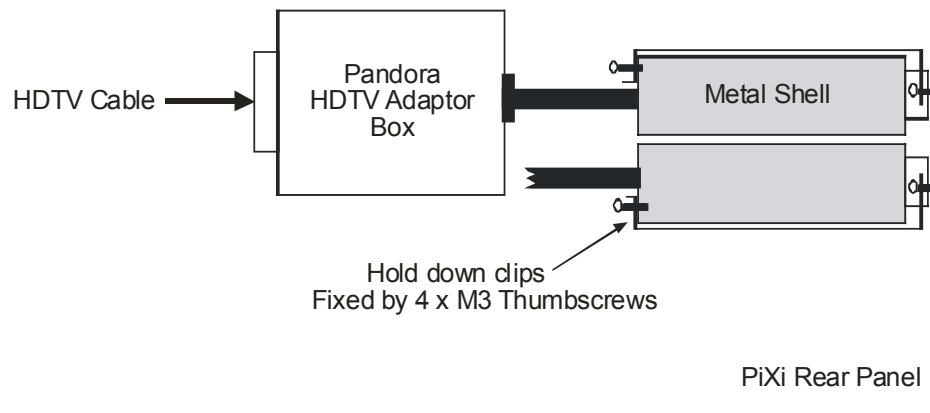

Note that a screw is used to secure the machined metal cover of the 50 way connector mated with the PiXi back panel.

HDTV 50 way parallel cables attach to the plastic box.

The adapter boxes must be installed at the PiXi end of any external wiring!!!

Inside the box you will find a series of links to allow configuration to the following wiring standards

- Panasonic 10 Bit

- Philips 10 Bit

- Panasonic 8 Bit

By default the links will be set to Panasonic 10 Bit mode but please change these if necessary.